

MC 50 C

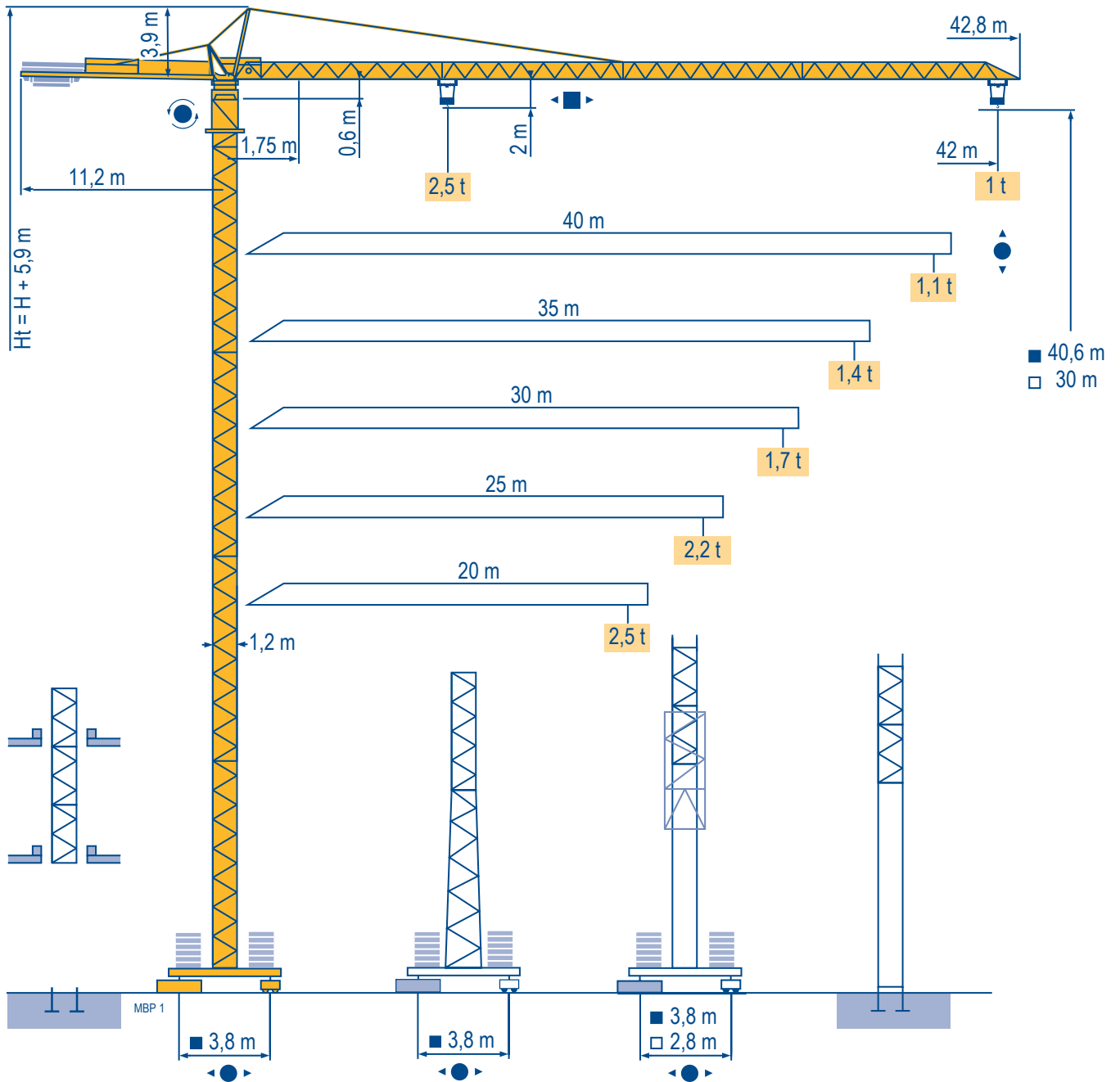

CITY CRANE

CE FEM 1.001-A3

Mat / Réactions □ 1,2 m
 Maste / Eckdrücke ▣ 20 m ⇒ 42 m
 Masts / Reactions
 Mástil / Reacciones
 Torre / Reazioni
 Tramo / Reações

MBP 2

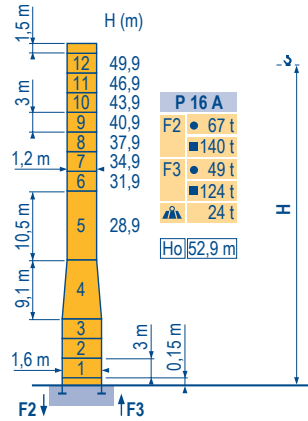
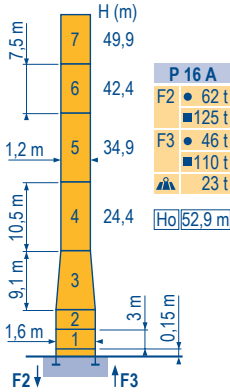
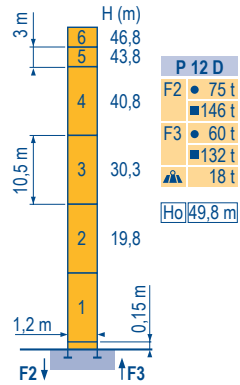
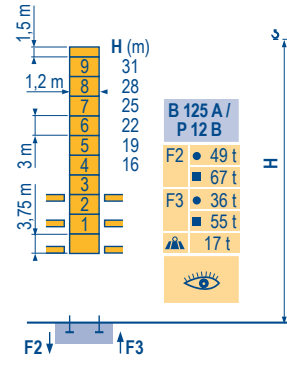
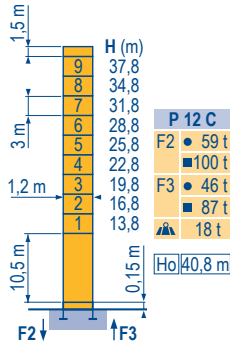
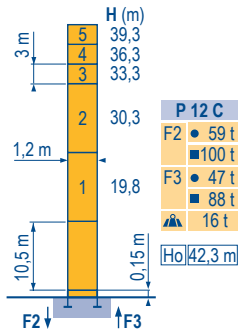

□ 1,2 m
 ▣ 20 m ⇒ 42 m

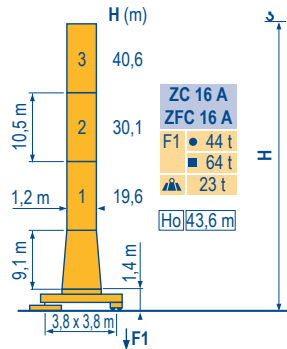
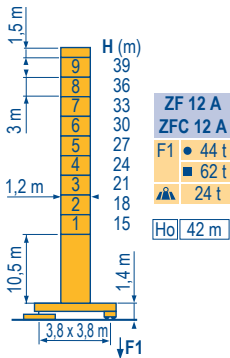
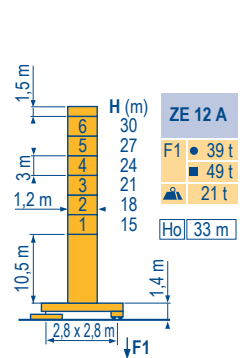

ZE - ZF - ZC - ZFC

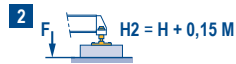

CITY CRANE
 MC 50 C



F	D	GB	E	I	P
● Réactions en service	● Reaktionskräfte in Betrieb	● Reactions in service	● Reacciones en servicio	● Reazioni in servizio	● Reações em serviço
▣ Réactions hors service	▣ Reaktionskräfte außer Betrieb	▣ Reactions out of service	▣ Reacciones fuera de servicio	▣ Reazioni fuori servizio	▣ Reações fora de serviço
👤 A vide sans lest (ni train de transport) avec flèche et hauteur maximum.	👤 Ohne Last, Ballast (und Transportachse), mit Maximalausleger und Maximalhöhe.	👤 Without load, ballast (or transport axles), with maximum jib and maximum height.	👤 Sin carga, sin lastre, (ni tren de transporte), flecha y altura máxima.	👤 A vuoto, senza zavorra (ne assali di trasporto) con braccio massimo e altezza massima.	👤 Sem carga (nem trem de transporte)- sem lastro com lança e altura máximas.
Ho H sans cabine	Ho Ohne Fahrerhaus	H without cab	H sin cabina	H senza cabina	H sem cabine

Courbes de charges
Lastkurven
Load diagrams
Curvas de cargas
Curve di carico
Curva de cargas

MBP 1

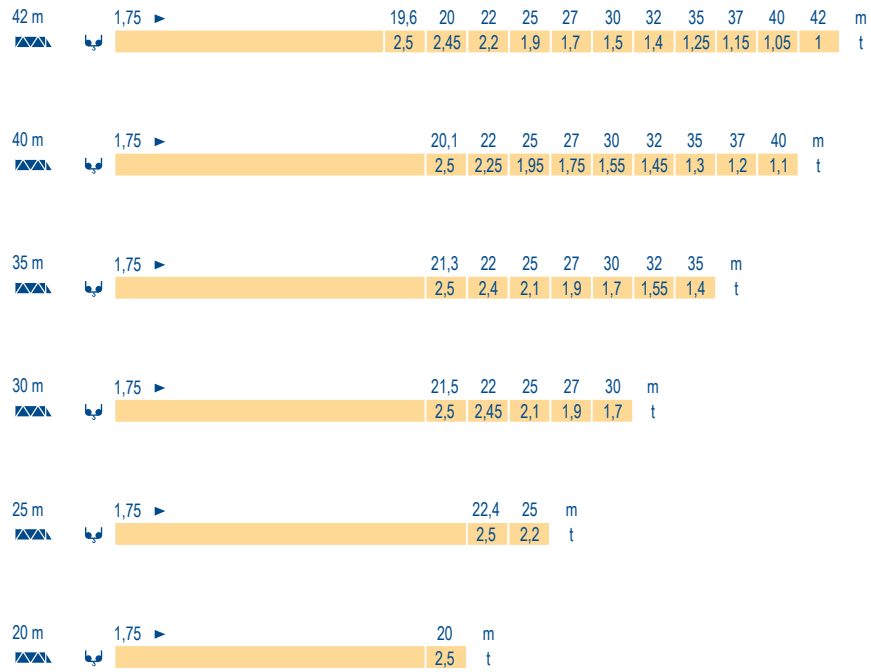

Télescopage sur dalles
Kletterkrane im Gebäude
Climbing crane
Telescopage gruas trepadoras
Gru in cavedio
Telescopagem sobre lages

MBP 1

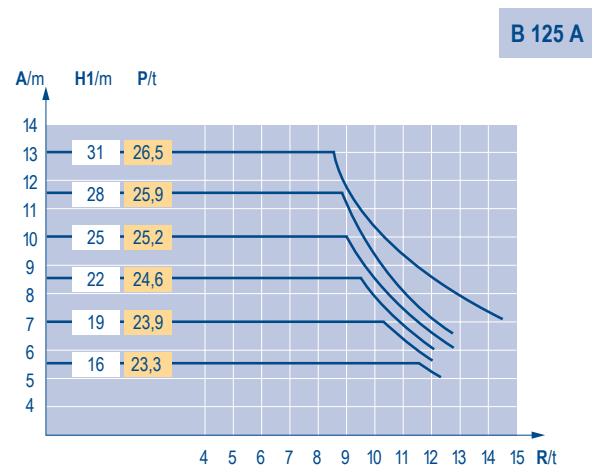
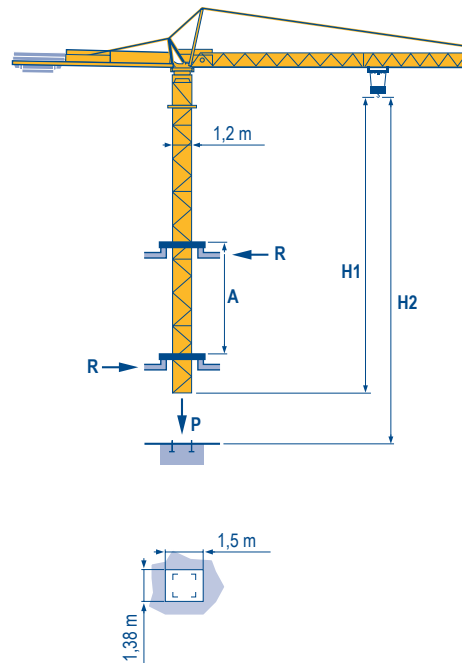

CITY CRANE
MC 50 C



	F	D	GB	E	I	P
A	Distance entre cadres	Abstand zwischen den Rahmen	Distance between collars	Distancia entra marcos	Distanza fra i telai	Distância entre quadros
H1	Hauteur grue	Kranhöhe	Crane height	Altura grúa	Altezza gru	Altura da grua
P	Poids de la grue(en service)	Krangewicht (in Betrieb)	Crane weight (in service)	Peso de la grúa (en servicio)	Peso della gru (in servizio)	Peso da grua (em serviço)
R	Réaction horizontale	Horizontalkräfte	Horizontal reaction	Reaccion horizontal	Reazione orizzontale	Reacção horizontal
	Voir télescopage sur dalles	Siehe Kletterkrane im Gebäude	See climbing crane	Veja grua trepadora	Consultare gru in cavedio	Ver telescopagem sobre lages

Mécanismes
Antriebe
Mechanisms
Mecanismos
Meccanismi
Mecanismos

MBP 3

						ch - PS hp	kW	
	15 PC 13 AC-1	m/min	7,1	21	42	15	11	130 m
		t	2,5	2,5	1,3			
	25 PC 13 AC-1	m/min	7,9	31,5	63	25	18	229 m
		t	2,5	2,5	1,3			
20 LVF 13	m/min	5 →	31 →	57 →	20	15	230 m	
	t	2,5	2,5	1,3				0,65
	3 D2 V5	m/min	21 - 42			3	2,2	
	RCV 40	tr/min U/min rpm	0 → 0,8			6	4,5	
	ZE - ZF 	TVD 324	26			2 x 4	2 x 2,9	
	ZC - ZFC 	RT 224	25			2 x 4	2 x 2,9	
		CEI 38	IEC 38			kVA		
		400 V (+6% -10%) 50 Hz			15 PC : 25 kVA 25 PC : 35 kVA 20 LVF : 30 kVA			

F	D	GB	E	I	P
Levage	Heben	Hoisting	Elevación	Sollevarmento	Elevação
Distribution	Katzfahren	Trolleying	Distribución	Distribuzione	Distribuição
Orientation	Schwenken	Slewing	Orientación	Rotazione	Rotação
Translation	Kranfahren	Travelling	Traslación	Traslazione	Translação

Document commercial non contractuel. Pour toute information technique se référer à la notice correspondante. Unverbindliches Vertriebsdokument. Für technische Informationen, siehe die entsprechenden Anweisungen. This commercial document is not legally binding. For any technical information, please refer to the corresponding instructions. Documento comercial non contractuel. Para cualquier información técnica, ver la noticia correspondiente. Documento commerciale non vincolante, per tutte le informazioni tecniche fare riferimento al catalogo istruzioni. Documento comercial não contractual. Para qualquer informação técnica complementar consultar as respectivas instruções.



Americas
Tel : +1 888 479 7278
Tel : +1 717 593 2000

Europe - Middle East - Africa
Tel : +33 (0) 4 72 81 50 00
Tel : +44 (0) 191 522 2000

Asia - Pacific
Tel : +65 6264 1188
Fax : +65 6862 4142

www.manitowoccrane.com

18, rue de Charbonnières - B.R.173
69132 ECULLY Cedex - France
Tél. : +33 (0) 4 72 18 20 20
Fax. : +33 (0) 4 72 18 20 00
www.manitowoccrane.com

CITY CRANE MC 50 C
Réf. 2004 42 MBP 4

Copyright.Reproduction interdite © POTAIN 2004

Réalisation Secdoc