

FLAT TOP TOWER CRANE



Specifications:

- ▶ Max jib length: 55,00 m
- ▶ Capacity at max length: 1,75 t
- ▶ Max capacity: 5,00 t

WORKS FOR YOU.™

KEY

Zeichenerklärung · Légende · Leyenda · Legenda · legenda · условные обозначения



Hoisting · Heben · Levage · Elevación · Sollevamento · Elevação · подъем



Trolleying · Katzfahren · Distribution · Distribución · Traslazione carrello · Distribuição · перемещение



Slewing · Schwenken · Orientation · Orientació · Rotazione · giro · поворот



Travelling · Schienenfahren · Translation · Traslación · Traslazione · Móvel · Движение



Directive on noise level · Richtlinie für den Schall-Leistungspegel · Directive sur le niveau acoustique · Directiva sobre el nivel acustico ·
Direttiva sul livello acustico · Diretiva sobre nível de ruídos · Директива по уровню шума



Consult us · Auf Anfrage · Nous consulter · Consultarnos · Consultateci · Consulte-nos · Проконсультироваться с нами



Power requirements · Geforderte Stromstärke · Puissance totale nécessaire · Potencia necesaria · Potenza totale richiesta ·
Requisitos de energia · Требования по питанию



Power supply · Stromversorgung · Alimentation · Alimentación · Alimentazione · Fonte de alimentação · Питание



In service · In Betrieb · En service · En servicio · In servizio · Em serviço · При работе



Out of service · Außer Betrieb · Hors service · Fuera de servicio · Fuori servizio · Fora de serviço · В режиме простоя



Max. under hook height · Höchste Hakenhöhe · Hauteur maxi. sous crochet · Maxima altura bajo gancho ·
Altezza max. sotto gancio · alt. máx. sob o gancho · макс высота до крюка



Without load, without ballast, max. jib and max. height · Ohne Last und Ballast, mit Maximalausleger und Maximalhöhe ·
A vide, sans lest, avec flèche et hauteur maximum · Sin carga, sin lastre, con pluma y altura máxima · A vuoto, senza zavorra,
braccio max., altezza max. · Sem carga, sem lastro, lança máxima, altura máxima · Без груза, без балласта, на макс. Длине вспомо-
гательной стрелы и макс. Высоте



Counterweight · Gegengewicht · Lest de contre-flèche · Lastre de contra flecha · Zavorra controbraccio · Contrapeso ·
Противовес

C25

FEM 1004 Out of service wind condition · FEM 1004 Windverhältnisse im Außerbetriebszustand · FEM 1004 Conditions de
vent hors service · FEM 1004 Condiciones de viento fuera de servicio · FEM 1004 Condizioni del vento in fuori servizio ·
FEM 1004 Condição do vento para fora de serviço · FEM 1004 Сила ветра, при которой работа запрещена

CONTENTS

CTT 121A-5 TS16

Inhalt · Contenu · Contenido · Indice · Sumário · содержание

Page · Seite · Page · Página · Pagina · Página · Страница:

Load Diagram · Lastkurven · Courbes de charges · Curvas de cargas · Diagramma di portata · diagrama de carga · схема нагрузок	4
Tower · Turm · Tour · Torre · Torre · Torre · Башня	6
Other configurations · Aufstellmöglichkeiten · Autres Implantations · Otras Implantaciones · Altre Installazioni · Outras configurações · Другие конфигурации	8
Mechanism · Antriebe · Mécanismes · Mecanismos · Meccanismi · mecanismo · механизм	9
Transportation · Transport · Transportation · Transportation · Trasporto · transporte · транспортировка	11

LOAD DIAGRAM

Lastkurven · Courbes de charges · Curvas de cargas · Diagramma di portata · Diagrama de carga · Схема нагрузок

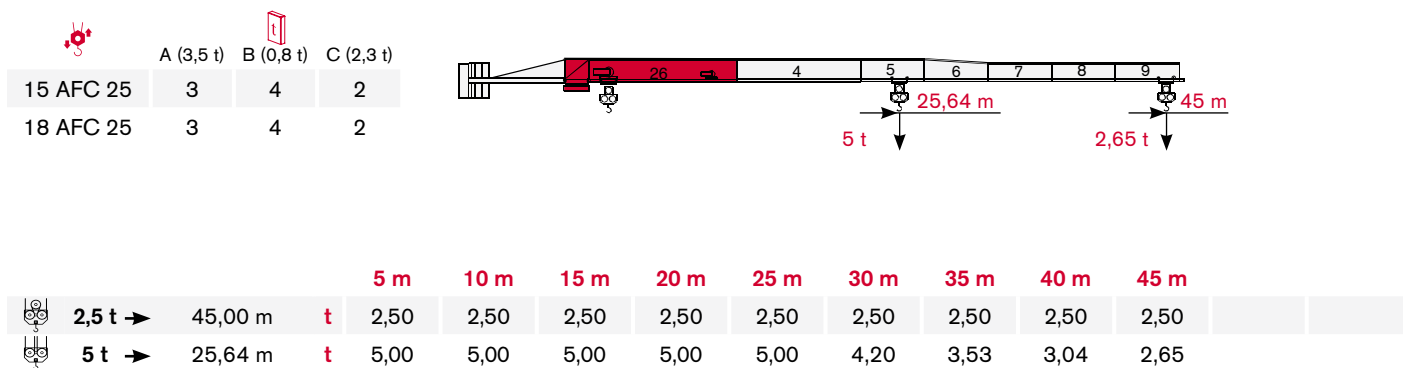
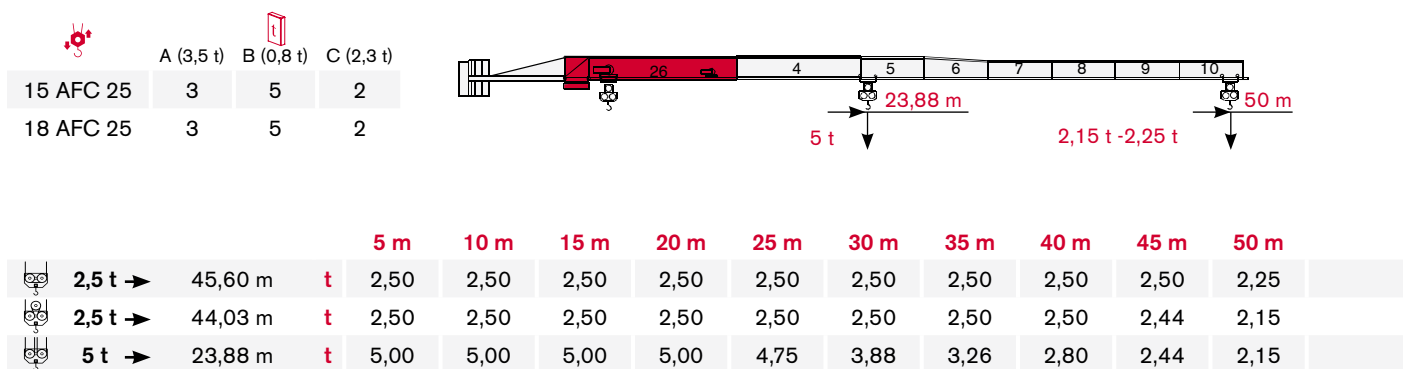
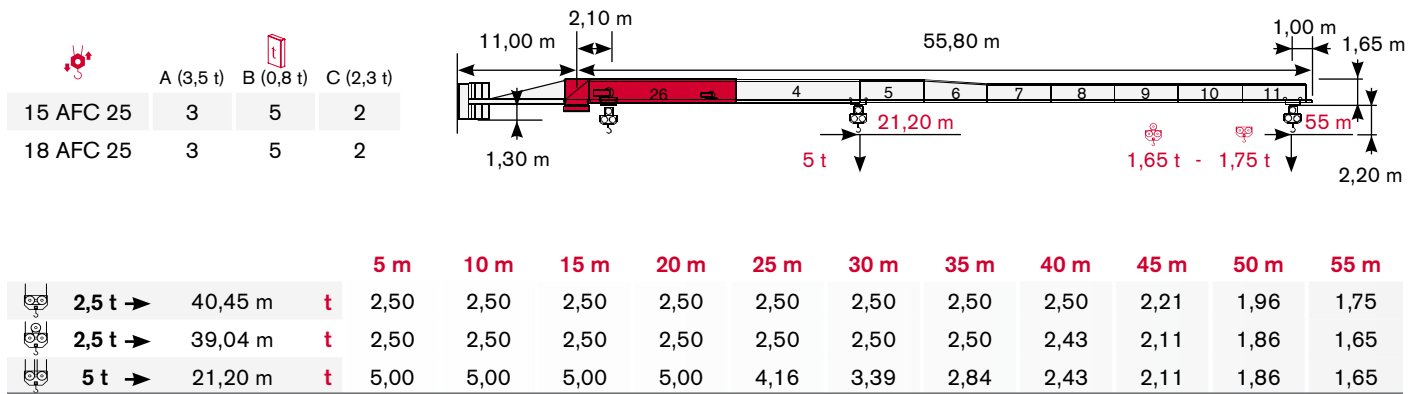

CTT 121A-5 TS16

	A (3,5 t)	B (0,8 t)	C (2,3 t)
15 AFC 25	5	0	0
18 AFC 25	5	0	0

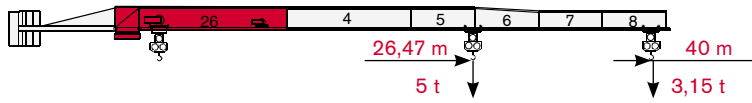

			5 m	10 m	15 m	20 m	25 m	30 m	35 m	40 m
2,5 t →	40,00 m	t	2,50	2,50	2,50	2,50	2,50	2,50	2,50	2,50
5 t →	26,47 m	t	5,00	5,00	5,00	5,00	5,00	4,35	3,66	3,15

	A (3,5 t)	B (0,8 t)	C (2,3 t)
15 AFC 25	4	0	1
18 AFC 25	4	0	1

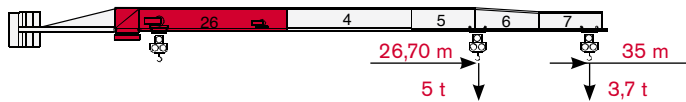

			5 m	10 m	15 m	20 m	25 m	30 m	35 m
2,5 t →	35,00 m	t	2,50	2,50	2,50	2,50	2,50	2,50	2,50
5 t →	26,70 m	t	5,00	5,00	5,00	5,00	5,00	4,40	3,70

	A (3,5 t)	B (0,8 t)	C (2,3 t)
15 AFC 25	3	0	2
18 AFC 25	3	0	2

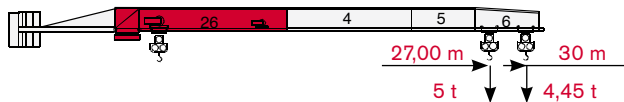

			5 m	10 m	15 m	20 m	25 m	30 m
2,5 t →	30,00 m	t	2,50	2,50	2,50	2,50	2,50	2,50
5 t →	27,00 m	t	5,00	5,00	5,00	5,00	5,00	4,45

TOWER

Turn · Tour · Torre · Torre · Torre · Башня

Standard Configurations · Standardkonfiguration · Standard Implantations ·
Implantaciones Standard · Installazioni Standard · Configuração padrão ·
стандартная конфигурация крана

Tower: TS16 & Basement: R1

	●	◊
R1	-1352 kN	-1943 kN
R2	1056 kN	1665 kN
	340 kN	

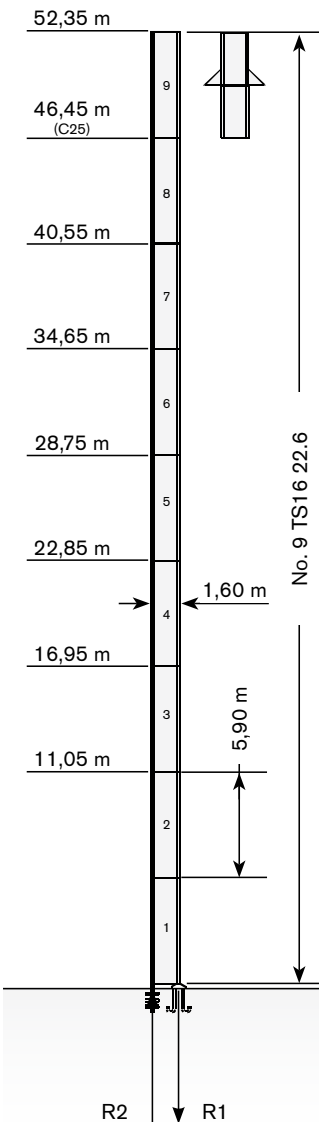

Tower: TS16 & Basement: F1

	●	◊
R1	-726 kN	-896 kN
R2	0 kN	0 kN
	330 kN	

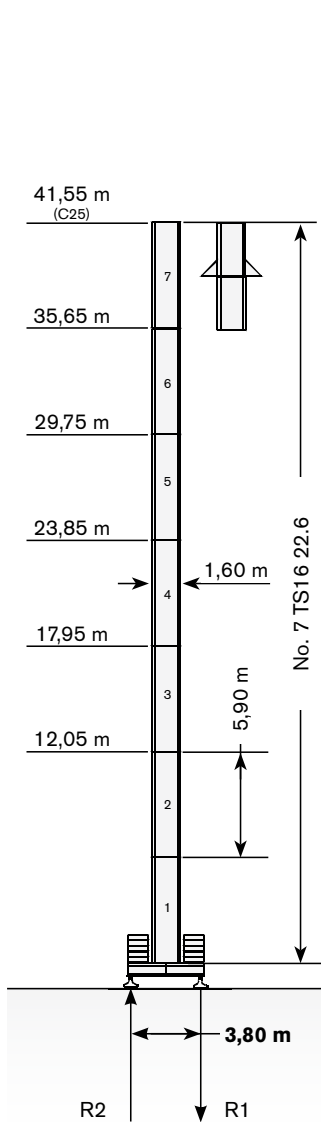

Tower: TS16 & Basement: FP1

	●	◊
R1	-726 kN	-896 kN
R2	0 kN	0 kN
	330 kN	

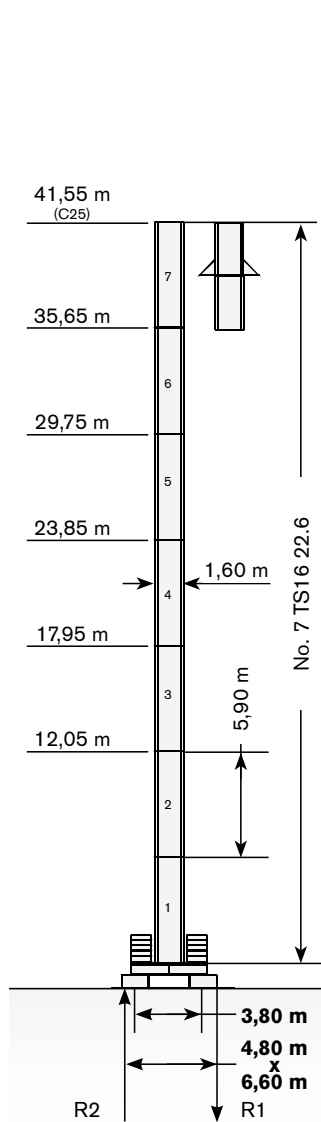

Tower: TS16 & Basement: T1

	●	◊
R1	-713 kN	-896 kN
R2	0 kN	-6 kN
	330 kN	

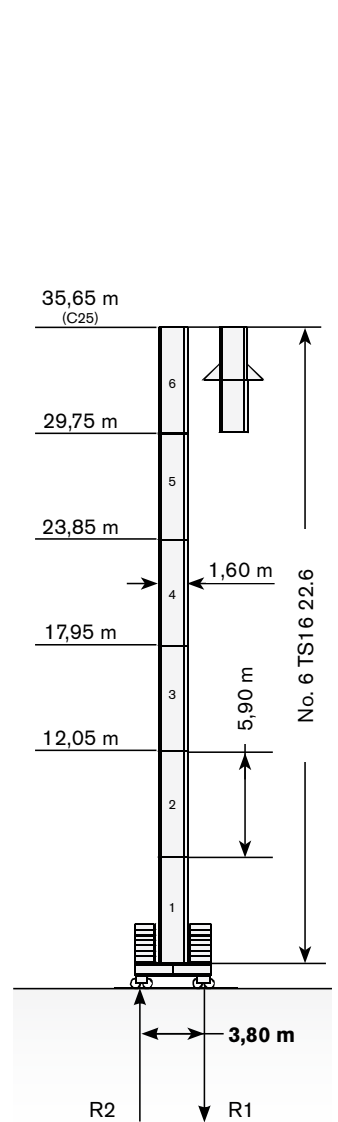

Max. under hook height · Höchste Hakenhöhe · Hauteur maxi. sous crochet · Maxima altura bajo gancho · Altezza max. sotto gancio · alt. max. sob o gancho · макс высота до крюка

Different heights and tower combinations are available; please consult us · Andere Höhen und Turmkombinationen auf Anfrage · Différentes hauteurs et combinaisons de tour sont disponibles; nous consulter · Hay diferentes alturas y combinaciones de torre disponibles. Consulté-nos · Altezze diverse e combinazioni di torre sono disponibili; consultateci · Diferentes alturas e combinações de torres disponíveis; fale conosco · Возможны другие сочетания высоты и конфигурации башни; проконсультируйтесь с нами

Tower: TS16 & Basement: F2

	●	◊
R1	-758 kN	-1039 kN
R2	0 kN	0 kN
	380 kN	

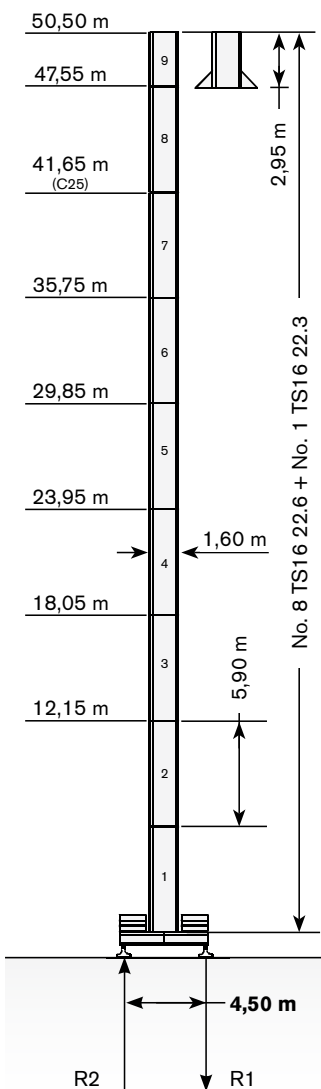

Tower: TS16 & Basement: FP2

	●	◊
R1	-758 kN	-1039 kN
R2	0 kN	0 kN
	380 kN	

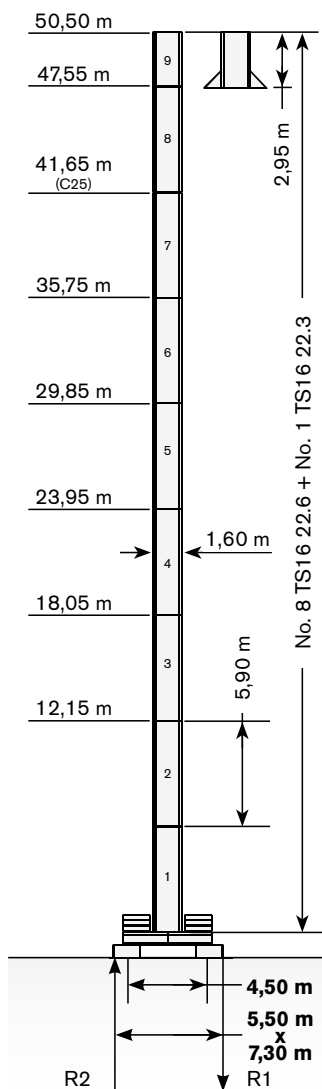

Tower: TS16 & Basement: T2

	●	◊
R1	-760 kN	-969 kN
R2	0 kN	0 kN
	369 kN	

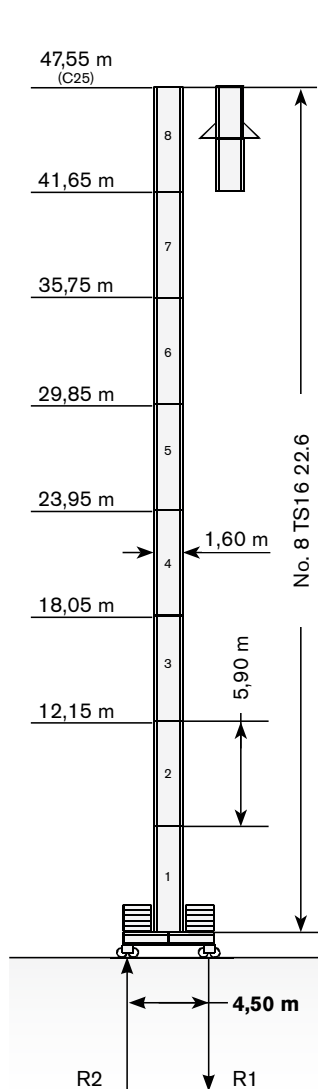

TS16 22.3 TC tower section for Top Climbing ·

Turmelement TS16 22.3 TC für Turm-Erhöhung mit Kletterwerk ·

Pylône tour TS16 22.3 TC pour surélévation avec cage télescopique ·

Columna torre TS16 22.3 TC por sobreelevación con jaula ·

TS16 22.3 TC elemento de torre para telescopagem ·

S16 22.3 TC секция башни TC для унарачивания крана

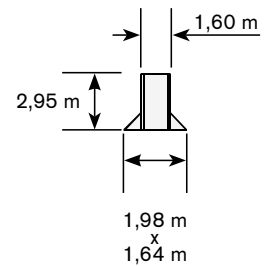

The available lengths for the TS tower sections are 11.8 m, 5.9 m, 2.95 m. • Die Turmschüsse TS sind mit Längen 11.8 m, 5.9 m, 2.95 m verfügbar. • Les éléments de mât TS sont disponibles en longueur 11.8 m, 5.9 m, 2.95 m. • Los tramos de torre TS son disponibles en las medidas de largo 11.8 m, 5.9 m, 2.95 m. • Le prolunghe TS sono disponibili in lunghezza 11.8 m, 5.9 m, 2.95 m. • Os comprimentos disponíveis para elementos de torre TS são: 11.8m, 5.9m e 2.95m. • Длина поставляемых секций башни TS - 11.8 м, 5.9 м, 2.95 м.

TOWER

Turn · Tour · Torre · Torre · Torre · Башня

Other configurations · Aufstellmöglichkeiten · Autres Implantations ·
Otras Implantaciones · Altre Installazioni · Outras configurações ·
Другие конфигурации

Bottom climbing crane · Kletterkran im Gebäude · Télescopage
sur dalles · Telescopage grúa trepadora · Gru climbing · Guindaste
automontante interno · Самоподъемный кран

Crane tied to the structure · Geankerter Kran · Grue ancrée ·
Grúa anclada · Gru ancorata · Guindaste ancorado na estrutura ·
Кран, крепящийся к сооружению

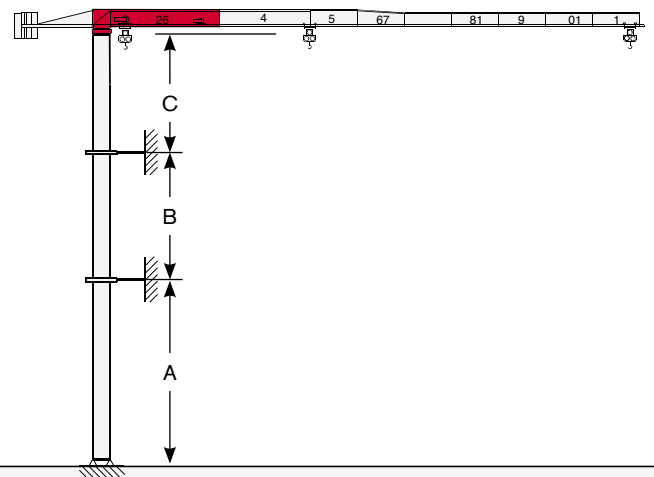
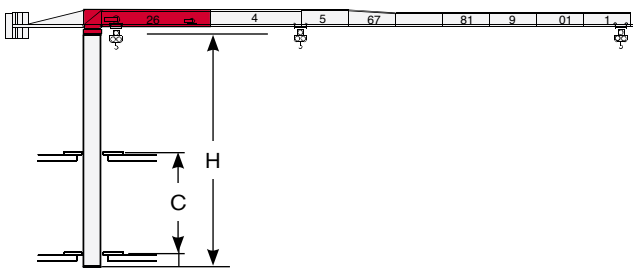

	min	max
C	11,00 m	13,00 m
H	29,50 m	44,25 m





	min	max
A	30,00 m	40,00 m
B	17,70 m	23,60 m
C	28,00 m	

MECHANISMS

CTT 121A-5 TS16







Antriebe · Mécanismes · Mecanismos · Meccanismi · Mecanismo · Механизм

Power supply · Stromversorgung · Alimentation · Suministro eléctrico · Alimentazione · Requisitos de energia · Требования по питанию

				
	15 AFC 25	41 kVA*	400V - 50Hz / 460V - 60Hz	2000/14/CE modificata
	18 AFC 25	42 kVA*	400V - 50Hz / 460V - 60Hz	2000/14/CE modificata

* Crane without travelling equipment – Three movements simultaneous at 90% · Krane ohne Schienenfahren – Drei gleichzeitige Bewegungen mit 90% · Grue sans translation – Trois mouvements simultanés à 90% · Grúa sin traslación – Tres movimientos contemporáneos hechos al 90% · Gru senza traslazione – Tre movimenti contemporanei al 90% · Guindaste sem equipamento de translação – três movimentos simultâneos a 90% · Кран без транспортируемого оборудования – движение груза в трех плоскостях возможно при 90% нагрузки

Hoisting · Heben · Levage · Elevación · Sollevamento · Elevação · Подъем

			t	m/min	kW			
	15 AFC 25 (Variant)		2,5	0 → 1,7	15	186 m		
			2,5	1,7 → 6				
			2,5	6 → 28				
			1,44	28 → 46				
		1,1	46 → 57					
			5	0 → 0,85				
			5	0,85 → 3				
	5		3 → 14					
	18 AFC 25 (Variant)		2,88	14 → 23			18	310 m
			2,2	23 → 28,5				
			2,5	0 → 2,2				
			2,5	2,2 → 8				
		2,5	8 → 34					
		1,46	34 → 55					
1,1		55 → 69						
	5	0 → 1,1						
	5	1,1 → 4						
	5	4 → 17						
			2,92	17 → 27,5				
			2,2	27,5 → 34,5				

MECHANISMS

Antriebe · Mécanismes · Mecanismos · Meccanismi · Mecanismo · Механизм

Hoisting Speed · Heben Geschwindigkeit · Vitesse de Levage ·
Velocidad de Elevación · Velocità' di Sollevamento · Velocidade de içamento ·
Скорость подъема

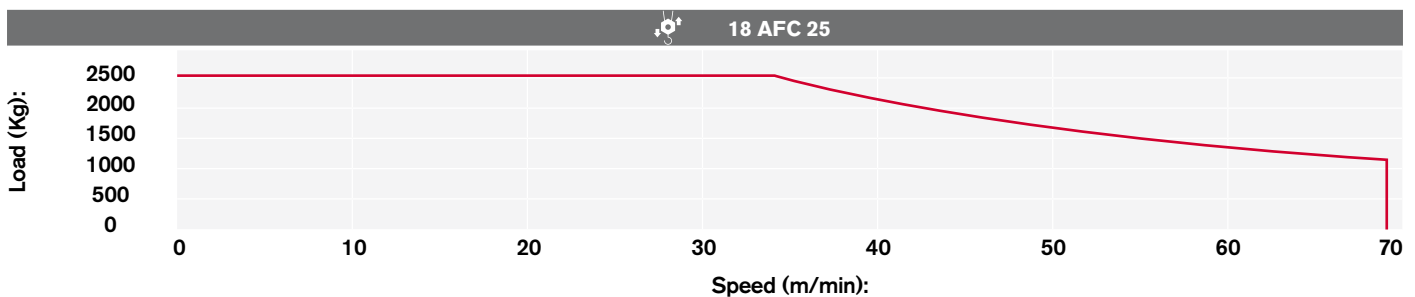
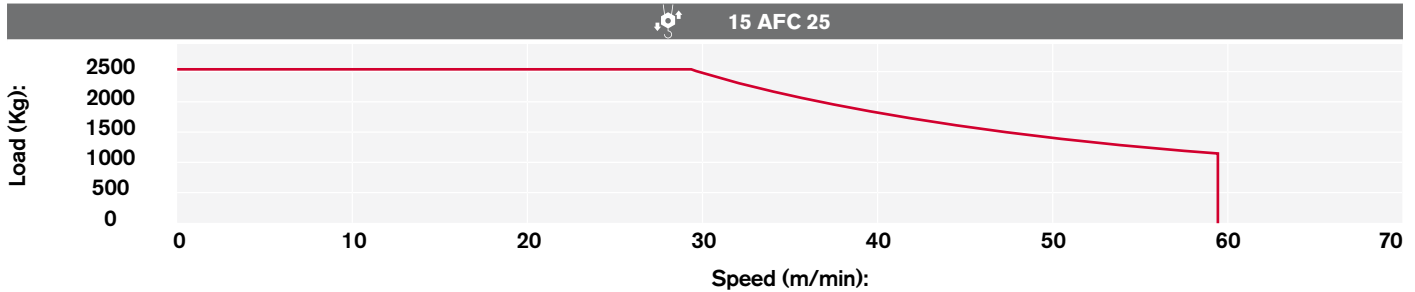

Additional Specifications · Weitere Leistungsdaten · Spécifications additionnelles · Otras prestaciones · Altre movimentazioni · Especificações adicionais ·
Дополнительные спецификации

	DVF 3 4 D5 (Variant)	0 → 6 → 30 → 60 m/min	4 kW
	SSR 1 1 80	0,84 r.p.m. (50Hz) 1 r.p.m. (60Hz)	1 x 80 Nm
	TAD 2RP 2M3	0 → 24 m/min (50Hz) 0 → 29 m/min (60Hz)	2 x 3 kW
	TAD 2RG 4M3	0 → 24 m/min (50Hz) 0 → 29 m/min (60Hz)	4 x 3 kW
	i		

Tower height max.



		T1	T2
	TAD 2RP 2M3	29,75 m	35,75 m
	TAD 2RG 4M3	> 29,75 m	> 35,75 m

TRANSPORTATION

CTT 121A-5 TS16

Transport · Transport · Conducción · Trasporto · Transporte · Транспортировка

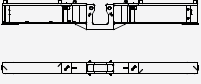
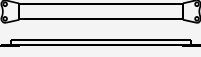
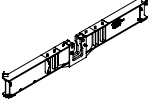
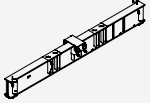
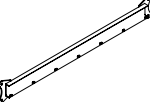
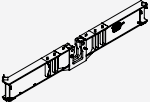
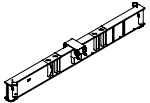

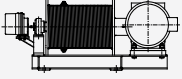



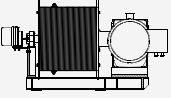
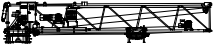

Packing list

CTT 121A-5/TS16	DESCRIPTION · BESCHREIBUNG · DESCRIPTION · DESCRIPCIÓN · DESCRIZIONE · DESCRIÇÃO · ОПИСАНИЕ	LENGTH · LÄNGE · LONGUEUR · LONGITUD · LUNGHEZZA · COMPRIMENTO · ДЛИНА	WIDTH · BREITE · LARGEUR · ANCHURA · LARGHEZZA · LARGURA · ШИРИНА	HEIGHT · HÖHE · HAUTEUR · ALTURA · ALTEZZA · ALTURA · ВЫСОТА	QUANTITY · MENGE · QUANTITÉ · CANTIDAD · CANTIDAD · QUANTITÀ · QUANTIDADE · КОЛИЧЕСТВО	WEIGHT · GEWICHT · POIDS · PESO · PESO · PESO · ВЕС
	"A" BEAM FOR C38 UNDERCARRIAGE TS16	5,80 m	0,41 m	0,80 m	1	2050 kg
	"B" BEAM FOR C38 UNDERCARRIAGE TS16	5,80 m	0,75 m	0,70 m	1	2050 kg
	CROSSBEAM FOR C38 UNDERCARRIAGE	3,70 m	0,11 m	0,40 m	2	190 kg
	"A" BEAM C45 UNDERCARRIAGE TS21-TS16	6,80 m	0,40 m	1,00 m	1	2820 kg
	"B" BEAM C45 UNDERCARRIAGE TS21-TS16	6,80 m	0,75 m	0,80 m	1	2620 kg
	CROSSBEAM FOR C45 UNDERCARRIAGE TS21-TS16	4,40 m	0,12 m	0,54 m	2	230 kg
	BEAM "A" FOR UNDERCARRIAGE C45 TS21-TS16	6,80 m	0,40 m	1,00 m	1	2820 kg
	BEAM "B" FOR UNDERCARRIAGE C45 TS21-TS16	6,80 m	0,75 m	0,80 m	1	2620 kg
	CROSSBEAMS UNDERCARRIAGE C45 TS21-TS16	4,40 m	0,12 m	0,54 m	2	230 kg
	TS16 22.3 TOWER SECTION	1,60 m	1,60 m	2,98 m	1	1215 kg*
	TS16 22.6 TOWER SECTION	1,60 m	1,60 m	5,93 m	1	2260 kg*
	CTT 121/A TS16 TOP CLIMBING UNIT TOWER SECTION MOUNT	2,50 m	2,00 m	3,00 m	1	1893 kg*
	HOIST WINCH 15 AFC 25	1,30 m	1,20 m	0,50 m	1	460 kg

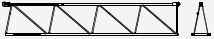
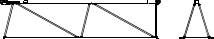
* Inclusive of ladder, ladder support and protection, platform

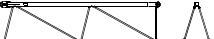
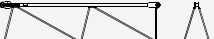
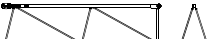
TRANSPORTATION

Transport · Transport · Conducción · Trasporto · Transporte · Транспортировка

CTT 121A-5/TS16	DESCRIPTION · BESCHREIBUNG · DESCRIPTION · DESCRIPCIÓN · DESCRIZIONE · DESCRIÇÃO · ОПИСАНИЕ	LENGTH · LÄNGE · LONGUEUR · LONGITUD · LUNGHEZZA · COMPRIMENTO · ДЛИНА	WIDTH · BREITE · LARGEUR · ANCHURA · LARGHEZZA · LARGURA · ШИРИНА	HEIGHT · HÖHE · HAUTEUR · ALTURA · ALTEZZA · ALTURA · ВЫСОТА	QUANTITY · MENGE · QUANTITÉ · CANTIDAD · QUANTITÀ · QUANTIDADE · КОЛИЧЕСТВО	WEIGHT · GEWICHT · POIDS · PESO · PESO · ВЕС
	HOIST WINCH 18 AFC 25	1,55 m	1,33 m	0,74 m	1	555 kg
	SLEWING UNIT INCLUDING JIB SECTION-26	11,80 m	2,60 m	2,50 m	1	6240 kg
	PLATFORM UNIT INCLUDING CAB	2,70 m	1,60 m	2,80 m	1	1160 kg
	COUNTERJIB COMPLETE	9,70 m	1,40 m	0,75 m	1	2240 kg
	JIB SECTION-4	10,00 m	1,11 m	1,80 m	1	1321 kg
	JIB SECTION-5	5,20 m	1,11 m	1,80 m	1	530 kg
	JIB SECTION-6	5,20 m	1,11 m	1,80 m	1	510 kg
	JIB SECTION-7	5,20 m	1,11 m	1,30 m	1	450 kg
	JIB SECTION-8	5,20 m	1,11 m	1,30 m	1	400 kg
	JIB SECTION-9	5,20 m	1,11 m	1,30 m	1	300 kg
	JIB SECTION-10	5,20 m	1,11 m	1,30 m	1	246 kg
	JIB SECTION-11	5,20 m	1,11 m	1,30 m	1	200 kg
	JIB POINT	1,20 m	0,70 m	1,10 m	1	55 kg
	BALLAST BASKET	1,40 m	0,90	2,70	1	265 kg

NOTES

CTT 121A-5 TS16

Notizen · Note · Apunte · Appunti · Notas · ноты

WORKS FOR YOU.™

NOTES

Notizen · Note · Apunte · Appunti · Notas · ноты

Effective Date: July 2013.

Product specifications and prices are subject to change without notice or obligation. The photographs and/or drawings in this document are for illustrative purposes only. Refer to the appropriate Operator's Manual for instructions on the proper use of this equipment. Failure to follow the appropriate Operator's Manual when using our equipment or to otherwise act irresponsibly may result in serious injury or death. The only warranty applicable to our equipment is the standard written warranty applicable to the particular product and sale and Terex makes no other warranty, express or implied. Products and services listed may be trademarks, service marks or trade-names of Terex Corporation and/or its subsidiaries in the USA and other countries. All rights are reserved. Terex® is a registered trademark of Terex Corporation in the USA and many other countries.

Gültig ab: Juli 2013.

Produktbeschreibungen und Preise können jederzeit und ohne Verpflichtung zur Ankündigung geändert werden. Die in diesem Dokument enthaltenen Fotos und/oder Zeichnungen dienen rein anschaulichen Zwecken. Anweisungen zur ordnungsgemäßen Verwendung dieser Ausrüstung entnehmen Sie bitte dem zugehörigen Betriebshandbuch. Nichtbefolgung des Betriebshandbuchs bei der Verwendung unserer Produkte oder anderweitig fahrlässiges Verhalten kann zu schwerwiegenden Verletzungen oder Tod führen. Für dieses Produkt wird ausschließlich die entsprechende, schriftlich niedergelegte Standardgarantie gewährt. Terex leistet keinerlei darüber hinaus gehende Garantie, weder ausdrücklich noch stillschweigend. Die Bezeichnungen der aufgeführten Produkte und Leistungen sind gegebenenfalls Marken, Servicemarken oder Handelsnamen der Terex Corporation und/oder ihrer Tochtergesellschaften in den USA und anderen Ländern. Alle Rechte vorbehalten. „TEREX“ ist eine eingetragene Marke der Terex Corporation in den USA und vielen anderen Ländern.

Date d'effet : Juillet 2013.

Les spécifications et prix des produits sont sujets à modification sans avis ou obligation. Les photographies et/ou dessins contenus dans ce document sont uniquement pour illustration. Veuillez vous référer à la notice d'utilisation appropriée pour les instructions quant à l'utilisation correcte de cet équipement. Tout manquement au suivi de la notice d'utilisation appropriée lors de l'utilisation de notre équipement ou tout acte autrement irresponsable peut résulter en blessure corporelle sérieuse ou mortelle. La seule garantie applicable à notre équipement est la garantie standard écrite applicable à un produit et à une vente spécifique. Terex n'offre aucune autre garantie, expresse ou explicite. Les produits et services proposés peuvent être des marques de fabrique, des marques de service ou des appellations commerciales de Terex Corporation et/ou ses filiales aux Etats Unis et dans les autres pays, et tous les droits sont réservés. «TEREX» est une marque déposée de Terex Corporation aux Etats Unis et dans de nombreux autres pays.

Fecha efectiva: julio 2013.

Los precios y las especificaciones de productos pueden sufrir cambios sin aviso previo u obligación. Las fotografías o dibujos de este documento tienen un fin meramente ilustrativo. Consulte el manual de instrucciones del operador correspondiente para más información sobre el uso correcto de este equipo. El hecho de no respetar el manual del operador correspondiente al utilizar el equipo o actuar de forma irresponsable puede suponer lesiones graves o fatales. La única garantía aplicable a nuestro equipo es la garantía escrita estándar correspondiente a cada producto y venta, y TEREX no amplía dicha garantía de forma expresa o implícita. Los productos y servicios mencionados pueden ser marcas registradas, marcas de servicio o nombres de marca de TEREX Corporation o de sus filiales en Estados Unidos de América y otros países, y se reservan todos los derechos. „TEREX“ es una marca comercial registrada de Terex Corporation en Estados Unidos de América y muchos otros países.

Data di inizio validità: luglio 2013.

Ci riserviamo il diritto di modificare le specifiche e i prezzi dei prodotti in ogni momento e senza preavviso. Le fotografie e/o i disegni contenuti in questo documento sono destinati unicamente a scopi illustrativi. Consultare le istruzioni sull'uso corretto di questo macchinario, contenute nell'opportuno Manuale dell'operatore. L'inottemperanza delle istruzioni contenute nel Manuale dell'operatore del macchinario e altri comportamenti irresponsabili possono provocare gravi lesioni, anche mortali. L'unica garanzia applicabile ai nostri macchinari è la garanzia scritta standard applicabile al particolare prodotto e alla particolare vendita; Terex è esonerata dal fornire qualsiasi altra garanzia, esplicita o implicita. I prodotti e servizi elencati possono essere dei marchi di fabbrica, marchi di servizio o nomi commerciali di TEREX Corporation e/o società affiliate negli Stati Uniti d'America e altre nazioni e tutti i diritti sono riservati. „TEREX“ è un marchio registrato di Terex Corporation negli USA e molti altri Paesi.

Data de vigência: julho 2013.

Especificações e preços dos produtos sujeitos a alteração sem aviso prévio ou obrigações. As fotografias e/ou desenhos deste documento servem apenas para fins ilustrativos. Consulte o respectivo Manual de Instruções para instruções sobre o uso correto deste equipamento. A falta de atenção ao respectivo Manual do Operador no uso de nosso equipamento ou a operação da máquina em condições impróprias pode resultar em lesão grave ou morte. A única garantia aplicável aos nossos equipamentos é a garantia padrão por escrito, aplicável ao produto específico e à sua venda, sem que nenhuma outra, expressa ou implícita, seja oferecida pela Terex. Os produtos e serviços listados podem ser marcas comerciais, marcas de serviço ou nomes-fantasia da Terex Corporation e/ou suas subsidiárias nos EUA e em outros países. Todos os direitos reservados. Terex® é marca registrada da Terex Corporation nos EUA e muitos outros países.

Вступает в силу: июль 2013 г.

Технические характеристики и цены могут изменяться без предварительного уведомления и без каких-либо обязательств для производителя. Фотографии и (или) чертежи, использованные в документе, приведены исключительно в качестве иллюстраций. Инструкции по правилам эксплуатации даются в соответствующих руководствах для операторов данного оборудования. Невыполнение рекомендаций руководства по эксплуатации нашего оборудования или другие безответственные действия могут повлечь серьезные травмы или смерть. Единственной гарантией, действующей в отношении нашего оборудования, является стандартная форма письменной гарантии на данный тип оборудования и на условия его продажи.



Copyright 2013 Terex Corporation

Terex Cranes, Global Marketing, Dinglerstraße 24, 66482 Zweibrücken, Germany
Tel. +49 (0) 6332 830, Email: info.cranes@terex.com, www.terexcranes.com

Brochure Reference: TC-DS-M-E/F/G//S/P/R-CTT121A-5 TS16-07/13

www.terexcranes.com



WORKS FOR YOU.™