

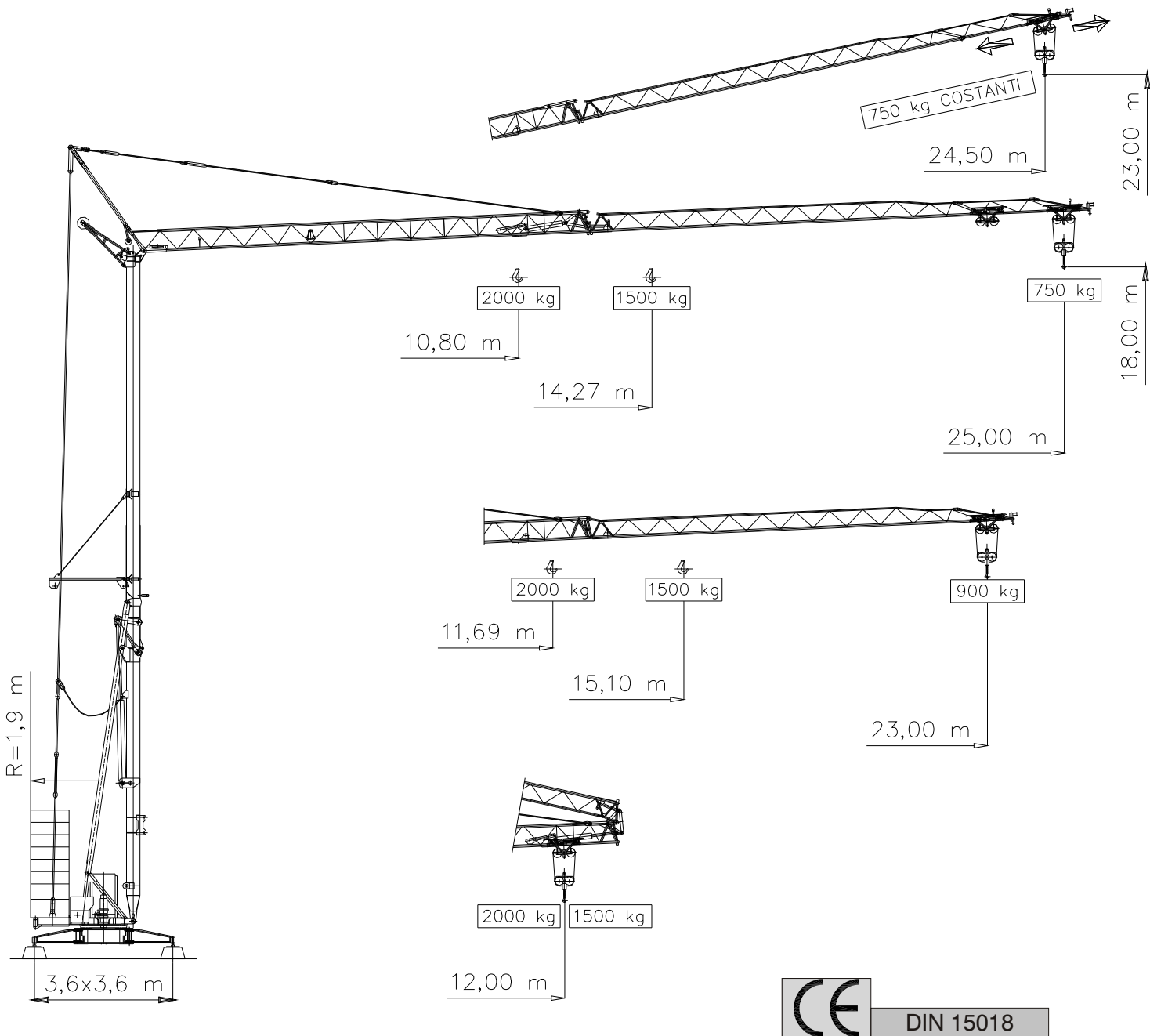

MaSol S.R.L.®
MACCHINE SOLLEVAMENTO

H.S. 23.09



MA.SOL. s.r.l.

Stabilimento ed uffici: via Buonarroti 26/7 26024 Paderno Ponchielli (CR) Italy - Mecc. Estero CR 010071

Tel.: +39 0374 367098 - Fax: +39 0374 367128 - E-mail: info@masol.it - Web: www.masol.it

Courtesy of Crane.Market

Courbes de charges - Lastkurven - Load curves - Curve di carico

P. Max. 1500 kg

25 m			14,27	15	17	19	21	23	25	m
			1500	1415	1230	1085	970	870	750	

23 m			15,1	17	19	21	23	m
			1500	1310	1160	1035	900	

P. Max. 2000 kg

25 m			10,8	13	15	17	19	21	23	25	m
			2000	1640	1415	1230	1085	970	870	750	

23 m			11,7	13	15	17	19	21	23	m
			2000	1770	1600	1310	1160	1035	900	

12 m **1500 - 2000 kg - cost.**

Flèche relevée - Ausleger in Steinstellung **750 kg - cost.**
Luffing jib - Braccio impennato

Mécanismes - Antriebe Mechanisms - Meccanismi

Gru a comandi totalmente elettronici

		m/min	kg	CV-PS hp	kw
Levage - Heben Hoisting - Sollevamento		Da 0 a 36	1500	7	5,14
Distribution - Katzfahren Trolleying - Carrello		Da 0 a 30		2	1,5
Orientation - Schwenken Slewing - Rotazione		Da 0 a 1 rpm - g/min		2,5 daNm	

Gru a comandi elettromeccanici

		m/min	kg	CV-PS hp	kw	
Levage Heben Hoisting Sollevamento	②		9	1500	2,5	1,83
			36	1000	7	5,14
	③		4,5	2000	2,5	1,83
			18	2000	10	7,35
			36	1000	10	7,35
Distribution - Katzfahren Trolleying - Carrello		30		2	1,5	
Orientation - Schwenken Slewing - Rotazione		0,2-1 rpm - g/min		2,5 daNm		

Puissance électrique nécessaire - Anschlusswert
Necessary electric power
Potenza elettrica necessaria

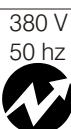

Réseau - Netzstrom
Mains supply - Potenza

10 kw 15 kw

Groupe électrogène
Stromaggregat - Generator set
Gruppo elettrogeno

Nous consulter
Auf Anfrage - Consult us
Consultarci

Modification réservées - Änderungen vorbehalten - Subject to modification - Con riserva di modifiche

Réactions - Eckdrucke - Reactions - Reazioni

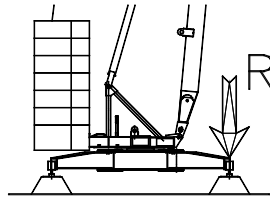

R ● 13000 daN ■ 9500 daN

● En service	● In Betrieb	● In service	● In servizio
■ Pas en service	■ Ausser Betrieb	■ Out of service	■ Fuori servizio

Poids de construction sans essieux - Konstruktionsgewicht ohne Transportachse
 Dead weight without transport axles - Peso della gru senza assali

8100 kg

Poids du lest - Ballastgewicht - Ballast weight - Peso zavorra rotante

13400 kg

Mode de transport - Transportart - Kind of transport - Soluzione di traino

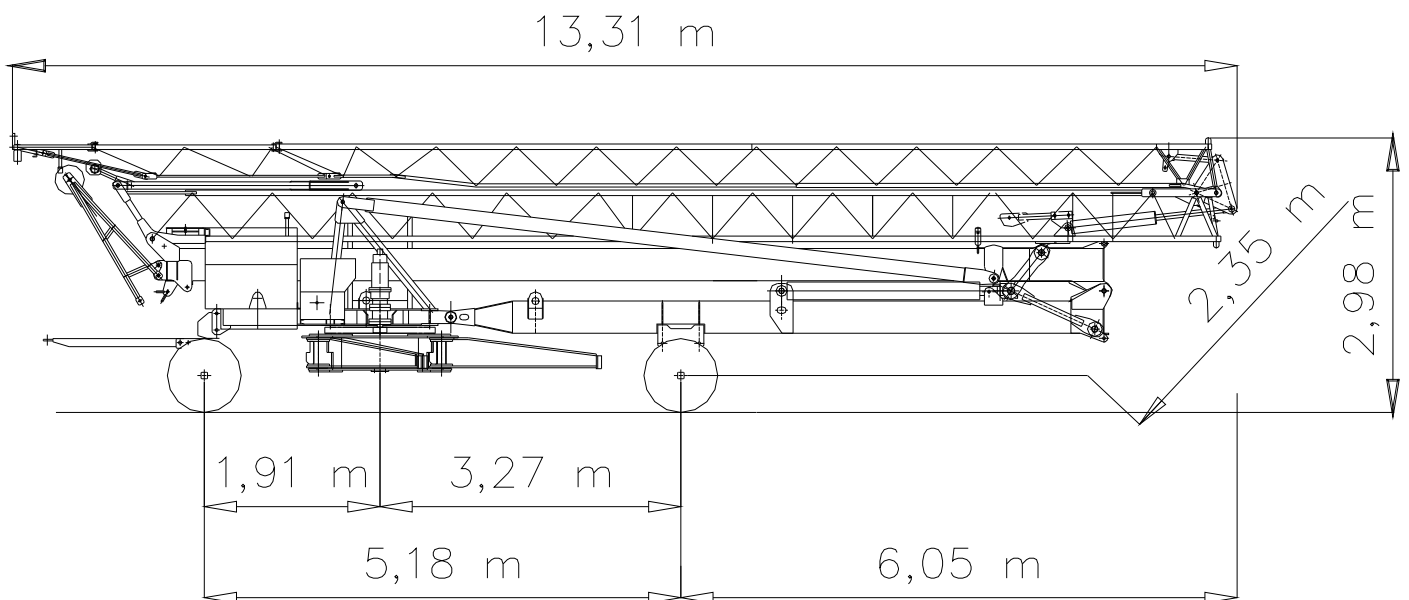

Montage - Montage - Erection - Montaggio

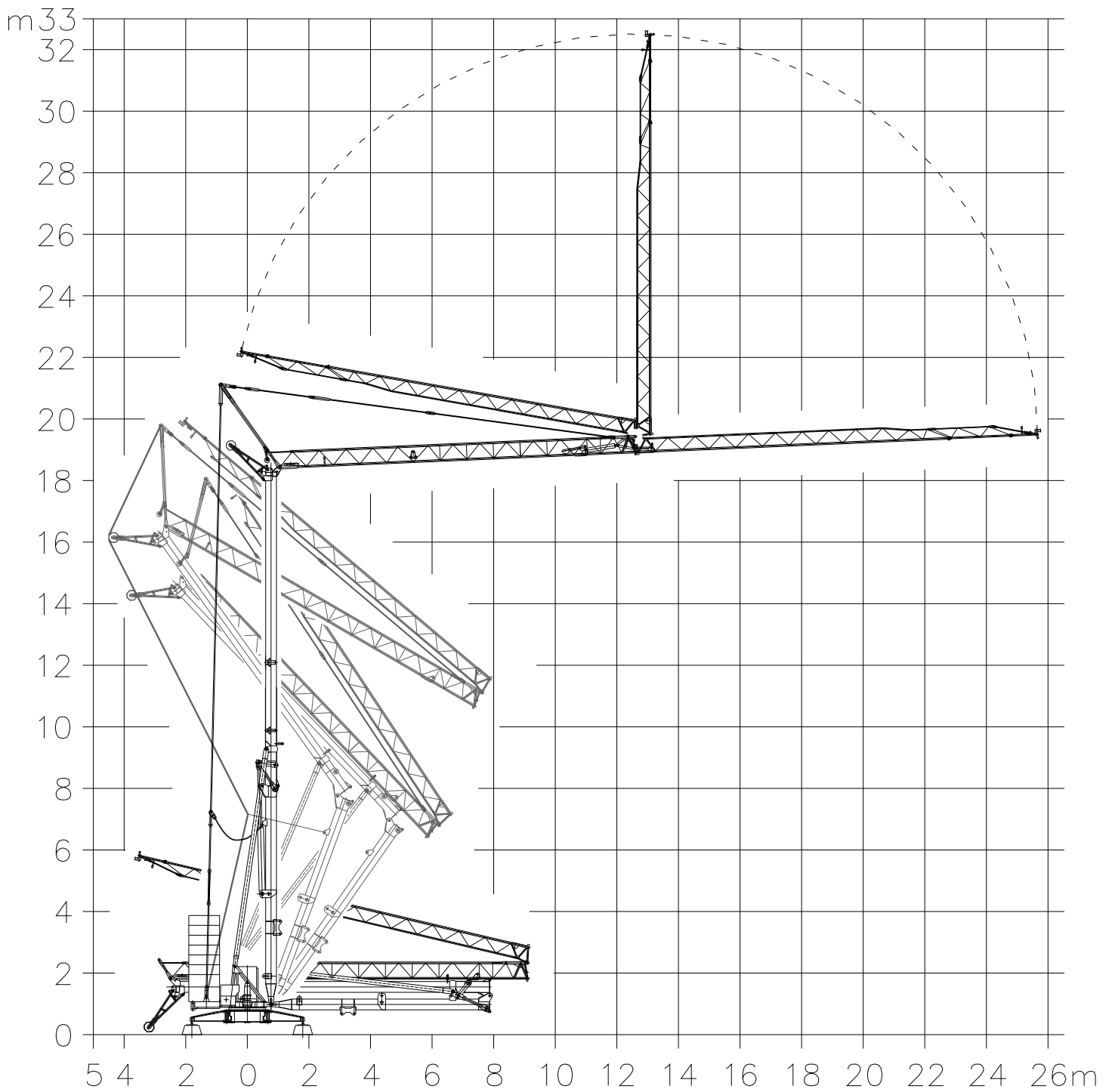

MA.SOL. s.r.l.
Stabilimento ed uffici:
via Buonarroti 26/7
26024 Paderno Ponchielli (CR) Italy
Mecc. Estero CR 010071
Tel. +39 0374 367098
Fax +39 0374 367128
E-mail: info@masol.it
Web: www.masol.it