

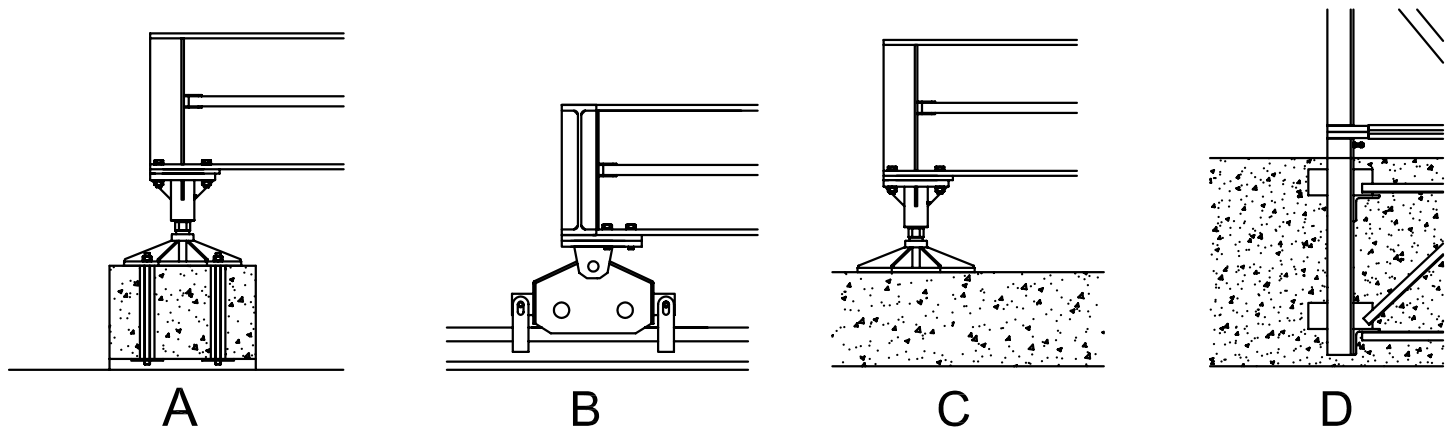

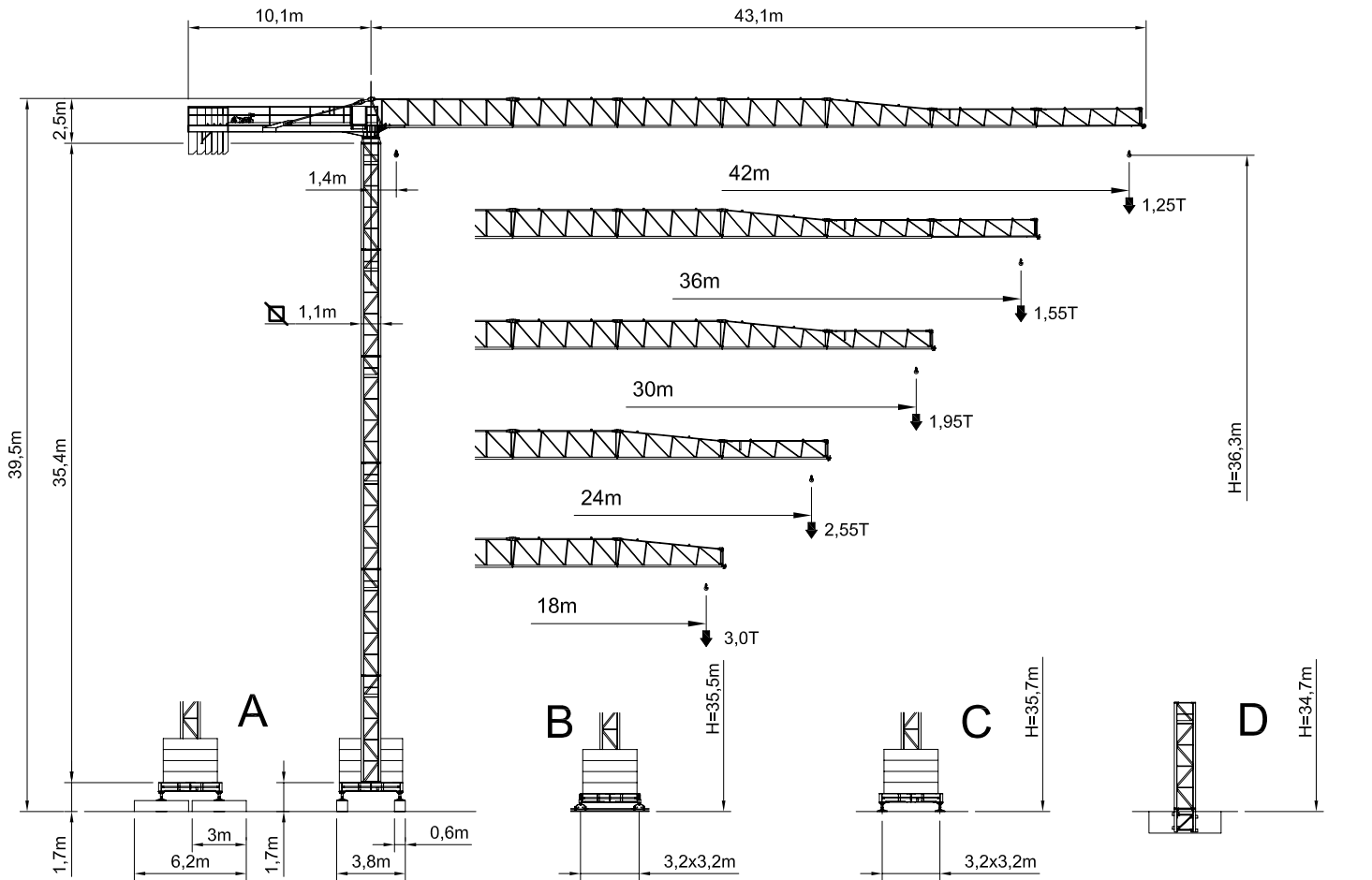





City Crane MR 45+3

GRU A TORRE A MONTAGGIO RAPIDO
«CITY TOWER CRANE»

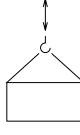

Portata max / Max s.w.l. Charge maxi / Max. Tragfähigkeit		2500 kg. 					3000 kg. 					4000 kg. 				
Braccio / Jib Ausleger / Flèche	m.	18	24	30	36	42	18	24	30	36	42	18	24	30	36	42
Campo di portata max da Max s.w.l. range from Charge maxi de Max. Tragfähigkeit von	1,4 m a to à bis	18,0	24,0	23,9	19,2	19,2	18,0	20,7	20,5	19,7	18,9	15,9	15,8	15,4	15,0	14,4
Raggi (m.) Radii (m.) Portée (m.) Ausladung (m.)	12	2500	2500	2500	2500	2500	3000	3000	3000	3000	3000	4000	4000	4000	4000	4000
	14	2500	2500	2500	2500	2500	3000	3000	3000	3000	3000	4000	4000	4000	4000	4000
	16	2500	2500	2500	2500	2500	3000	3000	3000	3000	3000	3971	3941	3839	3729	3576
	18	2500	2500	2500	2500	2500	3000	3000	3000	3000	3000	3500	3473	3383	3285	3150
	20		2500	2500	2500	2500		3000	3000	2934	2812		3102	3021	2934	2812
	22		2500	2500	2500	2500		2800	2727	2647	2537		2800	2727	2647	2537
	24		2500	2483	2410	2310		2550	2483	2410	2310		2550	2483	2410	2310
	26			2277	2210	2118			2277	2210	2118			2277	2210	2118
	28			2102	2040	1954			2102	2040	1954			2102	2040	1954
	30			1950	1892	1812			1950	1892	1812			1950	1892	1812
	32				1764	1689				1764	1689				1764	1689
	34				1650	1580				1650	1580				1650	1580
	36				1550	1483				1550	1483				1550	1483
	38					1397					1397					1397
40					1320					1320					1320	
42					1250					1250					1250	

Con sistema "ULTRALIFT" tutte le portate intermedie sono aumentate del 10% - All intermediate loads are increased of 10% if the crane is equipped with "ULTRALIFT" control - Les charges intermédiaires sont augmentées de 10% si la grue est équipée avec controle "ULTRALIFT"

		Velocità / Speed / Vitesse / Geschwindigkeit	Potenza / Power / Puissance / Leistung	
Rotazione - Slewing Orientation - Schwenken		0,37 / 0,7 / 1,0 min ⁻¹	4,0 Kw	
Carrello - Trolley Chariot - Katzfahren		20 / 41,3 m/min	1,1/2,2Kw	
Traslazione - Rail Translation - Kranfahren		13 m/min	2 x 2,9 Kw	
Argano Winch Treuil Hubwerk		Marcla Step Vitesse Gang	Carico / velocità - Load / speed Charge / vitesse - Tragfähigkeit / Geschwindigkeit	
				
Tipo Type Type Typ	15 HP 11 Kw - 4 / 4 VF	1	2000 Kg - 7 m/min	4000 Kg - 3,5 m/min
		2	2000 Kg - 28 m/min	4000 Kg - 14 m/min
		3	1000 Kg - 56 m/min	2000 Kg - 28 m/min
	15 HP 11Kw - 2,5 / 2,5 VF	1	2500 Kg - 5,2 m/min	-
		2	2500 Kg - 21 m/min	-
		3	1250 Kg - 42 m/min	-
	25 HP 18,4 Kw - 3	1	3000 Kg - 7,5 m/min	-
		2	3000 Kg - 30 m/min	-
		3	1500 Kg - 60 m/min	-
	25 HP 18,4 Kw - 3VF	1	3000 Kg - 7,5 m/min	-
		2	3000 Kg - 30 m/min	-
		3	1500 Kg - 60 m/min	-
4		1000 Kg - 72 m/min	-	

Conforme alla direttiva 2000/14/CE sul livello acustico - In compliance with the 2000/14/CE instruction on noise level - Conforme à directive 2000/14/CE sur le niveau acoustique
Gemäss 2000/14/CE über Schall - Leistungspegel - Conforme con la directive 2000/14/CE sobre el nivel acustico.

FORZA MOTRICE TOTALE TOTAL INSTALLED POWER PUISSANCE TOTALE DES MOTEURS GESAMT-MOTORENLEISTUNG	11Kw (15HP)	18,4Kw (25HP)
	23 Kw	31 Kw

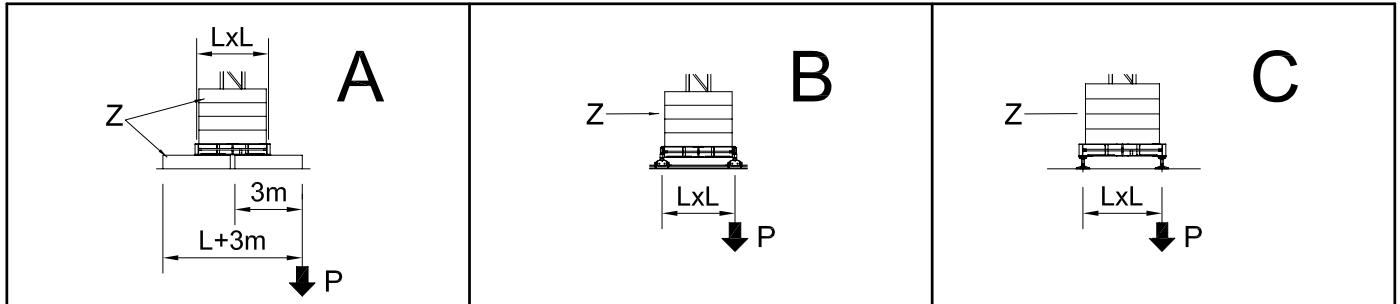

SU BASE / ON CROSSBASE SUR CHASSIS / AUF KREUZRAHME			L = 3,2 m					
H (m)	max. Z (t)	P (t)	H (m)	max. Z (t)	P (t)	H (m)	max. Z (t)	P (t)
36,3	60,4	57,3	35,5	60,6	54,9	35,7	60,6	55,7
30,4	45,2	38,8	29,6	45,5	36,9	29,8	45,5	37,5
24,5	40,2	32,5	23,7	40,4	32,0	23,9	40,4	32,2
18,6	40,2	29,1	17,8	35,4	28,4	18,0	35,4	28,6

SU PLINTO / STATIONARY SUR PIEDS DE SCELLEMENT / STATIONAR										
	H (m)	11,1	17,0	22,9	28,8	34,7		H (m)	39,1	43,1
	T (t)	41,7	46,2	52,2	60,3	86,1		T (t)	107,2	134,2
	P (t)	50,3	55,4	62,1	70,7	97,9		P (t)	120,4	147,2

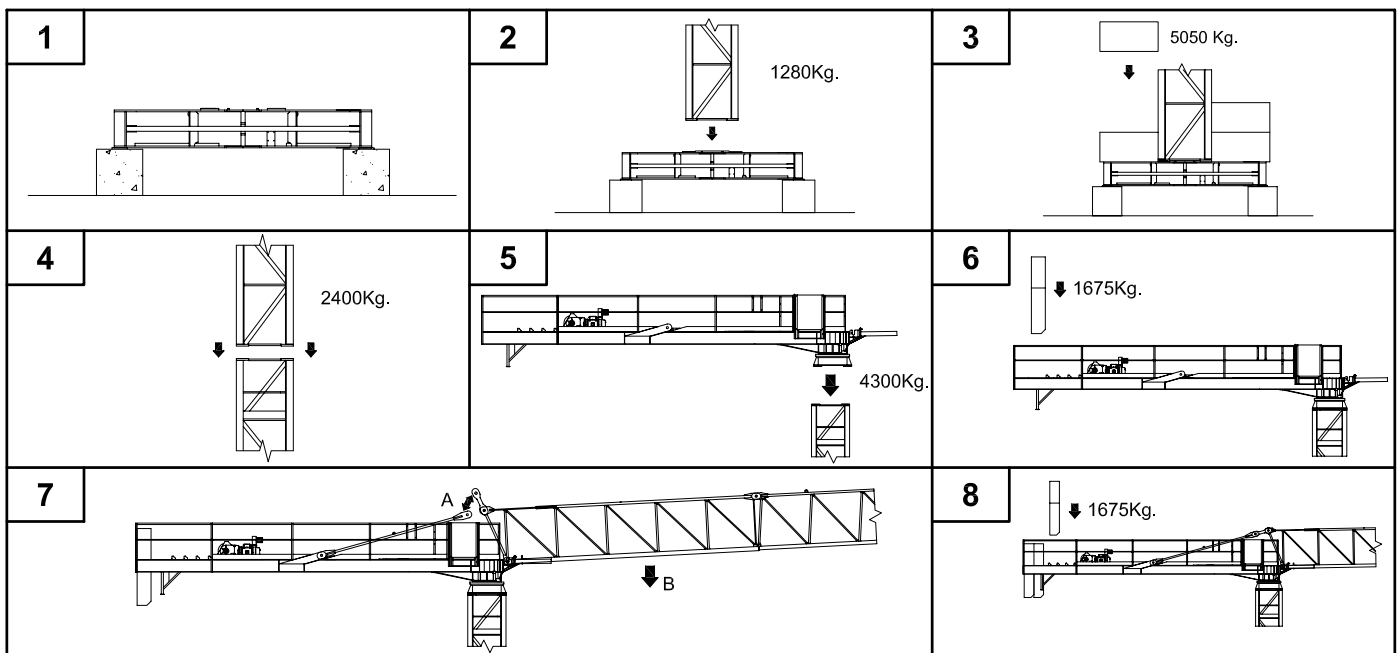

CARLO RAIMONDI FU R. SPA

Corso Garibaldi, 253
 20025 Legnano - ITALY
 Tel. 0331 / 548061-450239
 FAX. 0331 / 450400
 E-MAIL - info@raimondigr.it