

# Gru automatica idraulica SMH 282

## Le gru San Marco

-  San Marco Cranes
-  San Marco Kräne
-  Les grues San Marco
-  Las gruas San Marco

**SMH** Gru automatica idraulica  
Automatic crane hydraulic  
Automatischer Hydraulischer Kran  
Grue automatique hydraulique  
Grua automatica hidraulica

**SMK** Gru a torre montaggio modulare  
Tower crane modular assembly  
Turmdrehkran modulare montage  
Grue a tour montage modulaire  
Grua torre montaje modular

		L (m)																						
		12	14	16	18	20	22	24	25	26	27	28	30	32	35	36	40	45	46	50	51	57	60	
SMK	44																	2500		2000	1500	1250		
	39																	2500		2000	1500	1250		
SMH	38																	1500		1000	800	600		
	35																	1500		1000	800	600		
	28																	1500		1000	800	600		
	26																	1400		1000	800	600		
	22																	1400		1000	800	600		
	22																	1400		1000	800	600		
	18																	1400		1000	800	600		
	18																	800		700	700	700		
	18																	800		700	700	700		
	16.5																	700		600	600	600		
	15.5																	700		600	600	600		
14																	600		500	500	500			

Strutture in acciaio ad alta resilienza per impiego a basse temperature • Zincatura torre e braccio con immersione a caldo secondo ISO 1461 • Bassa emissione acustica e livello di potenza sonora garantito e certificato • Climatizzazione termostatica dell'equipaggiamento elettrico per alte e basse temperature • Dispositivi di autolivellamento e autozavorramento • Mezzi di accesso alla parte superiore della gru a posizionamento programmabile e equipaggiamento di sicurezza.

 High resilience steel structures to be used at low temperature • Galvanised tower and jib with hot dipping in conformity ISO 1461 • Guaranteed and certified low acoustics emission and sound powers level • Automatic temperature control of electrical equipment for high and low temperatures • Full automatic devices for self levelling and ballast loader • Disassembled stair on the tower with security device.

 Strukturen aus besonders schlagfesten Stahl für den Einsatz bei niedrigen Temperaturen • Turm und Ausleger lt. ISO 1461 heißverzinkt • Niedriger Geräuschpegel und Schalleistungsniveau garantiert und zertifiziert • Thermostatgesteuerte Klimatisierung der elektrischen Ausrüstung für hohe und niedrige Temperaturen • Vorrichtungen zur Selbstnivellierung und Selbstballastierung • Ausrüstungen für den Zugang zum oberen Teil des Krans mit programmierbarer Positionierung und Sicherheitsvorrichtung.

 Charpente en acier à haute résilience pour utilisation en température ambiante froide • Galvanisation à chaud mat et flèche par immersion selon ISO 1461 • Émission acoustique réduite et niveau de puissance sonore garantie avec certificat • Climatization thermostatique de l'équipement électrique pour températures ambiante élevées ou basses • Dispositifs automatiques de mise à niveau et de lestage • Escaliers d'accès au mat démontables avec dispositif de protection.

 Estructura en acero de alta resistencia para uso a baja temperaturas • Zincado en caliente de la torre y flecha según normativa ISO 1461 • Baja emisión acústica y nivel de potencia sonora garantizada y certificada • Climatización termostática del equipamiento eléctrico para bajas y altas temperaturas • Dispositivos de autonivelamiento y auto cargado del lastre • Medios de acceso a la parte superior de la grúa con posicionamiento programable y equipos de seguridad.

- Conforme alle direttive CEE: 89/392; 91/368; 93/44; 93/68 e 98/37 direttiva macchine
- Conforme alle direttive CEE: 2000/14 e 87/405 livello acustico
- Conforme alle direttive CEE: 89/336 compatibilità magnetica
- Conforme alle direttive CEE: 73/23 bassa tensione
- Conforme al D.P.R. 27/4/55 n. 547
- Le nostre macchine sono protette da assicurazione per responsabilità civile prodotti senza termine
- Specifiche suscettibili di variazioni senza preavviso.

-  • In compliance with the EEC 89/392; 91/368; 93/44; 93/68 and 98/37 regulations
- In compliance with the EEC 2000/14 and 87/405 regulations on noise levels
- In compliance with the EEC 89/336 regulations on electromagnetic compatibility
- In compliance with the EEC 73/23 regulations on electrical equipment
- Machine covered by lifetime public liability insurance coverage
- Specifications subject to modification without notice.





-  • Gemäss EWG Richtlinien 89/392; 91/368; 93/44; 93/68 und 98/37
- Gemäss EWG Richtlinien 2000/14 und 87/405 über schall-leistungspegel
- Gemäss EWG Richtlinie 89/336 über Elektromagnetische Verträglichkeit
- Gemäss EWG Richtlinie 73/23 über Elektrische Ausrüstung
- Maschine unter Produkt-Haftpflichtversicherungsschutz ohne Fristangabe
- Obiges kann ohne Berstaendigung geaendert werden.

-  • Conforme à les directives CEE 89/392; 91/368; 93/44; 93/68 et 98/37
- Conforme à les directives CEE 2000/14 et 87/405 sur le niveau acoustique
- Conforme à la directive CEE 89/336 sur la compatibilité électromagnétique
- Conforme à la directive CEE 73/23 sur l'équipement électrique
- Machines assurées pour la responsabilité civile des produit sans échéance
- Specifications susceptibles de modification sans avis préalable.

-  • Conforme con las directivas CEE 89/392; 91/368; 93/44; 93/68 y 98/37
- Conforme con las directivas CEE 2000/14 y 87/405 sobre el nivel acustico
- Conforme con la directiva CEE 89/336 sobre la compatibilidad magnetica
- Conforme con la directiva CEE 73/23 sobre baja tension
- Máquina protegida y asegurada por la responsabilidad civil de productos todo riesgo
- Especificaciones sujetas a modificaciones sin previo aviso.

95.15.00282.001.1

Timbro rivenditore

-  Automatic crane hydraulic
-  Automatischer Hydraulischer Kran
-  Grue automatique hydraulique
-  Grua automatica hidraulica

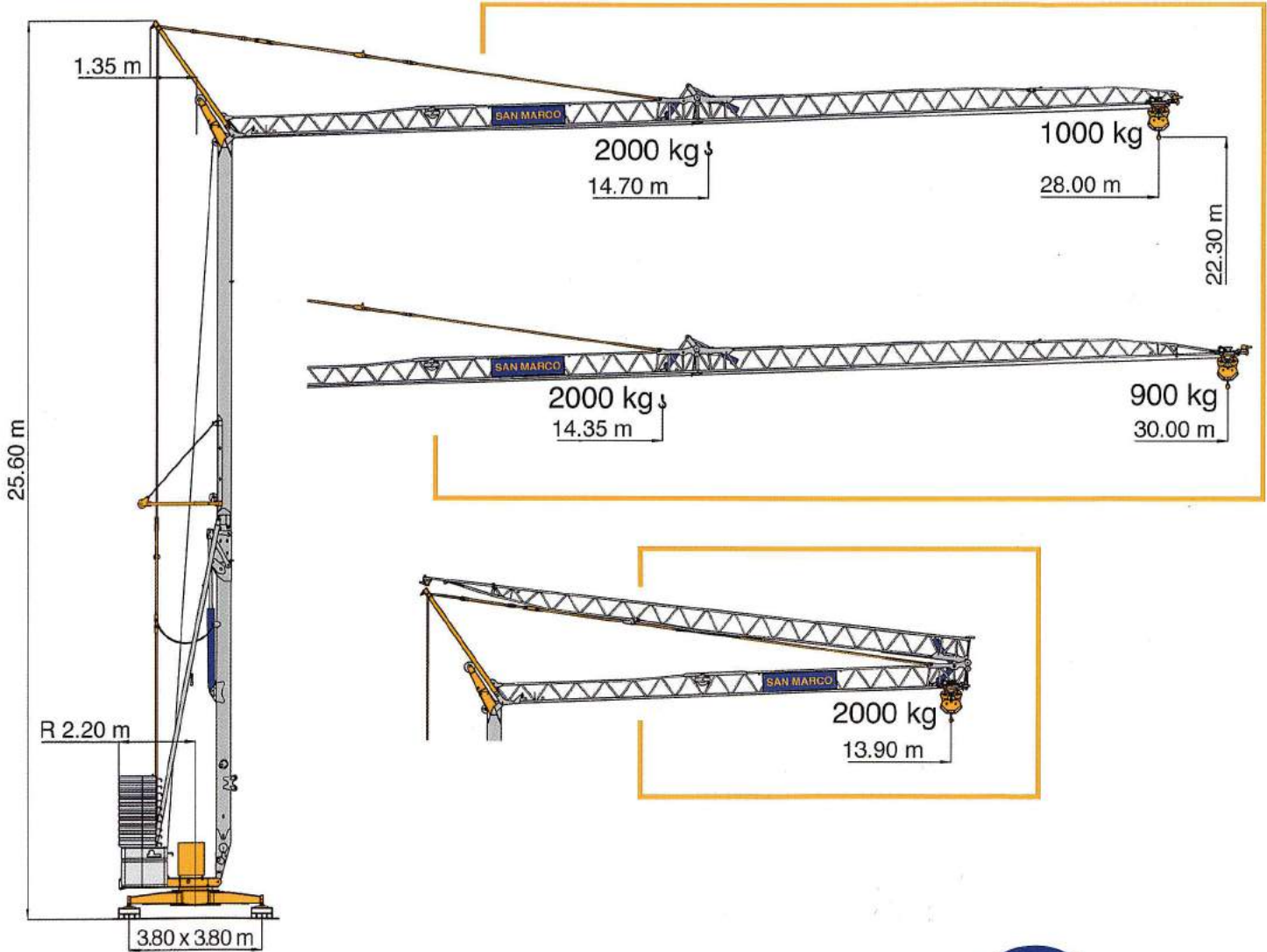
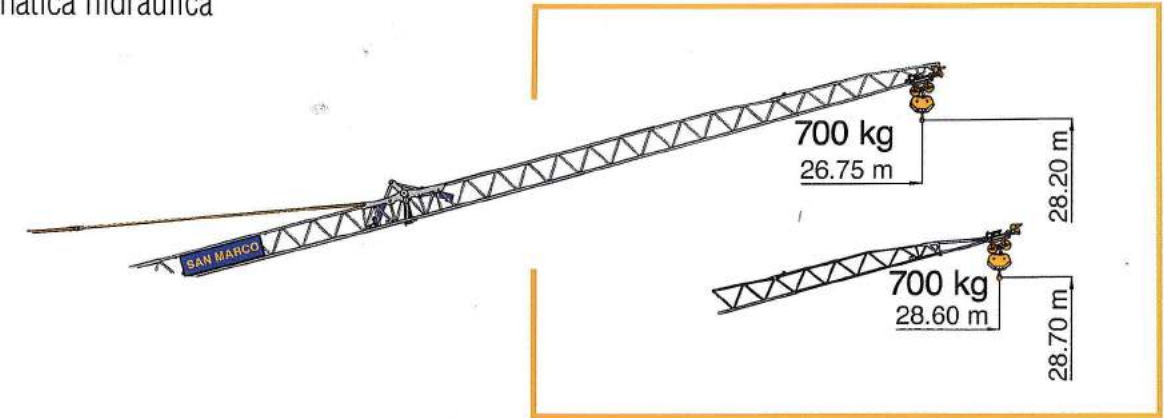

  
**SAN MARCO**  
INTERNATIONAL  
COSTRUZIONI GRU - BETONIERE  
E ATTREZZATURE EDILI  
**SAN MARCO INTERNATIONAL s.r.l.**  
via Principe Umberto, 42/B - 28021 Borgomanero (No) Italy  
tel. 0322 82601 (4 linee r.a.) - fax 0322 846035  
www.sanmarco-int.com sanmarco@sanmarco-int.com

  
DIN 15018 H1 B3  
ISO 4301

  
**SAN MARCO**  
INTERNATIONAL

# Gru automatica idraulica **SMH 282**

## Montaggio

- Erection
- Montage
- Montage
- Montaje

kW	2.3
Hp	3

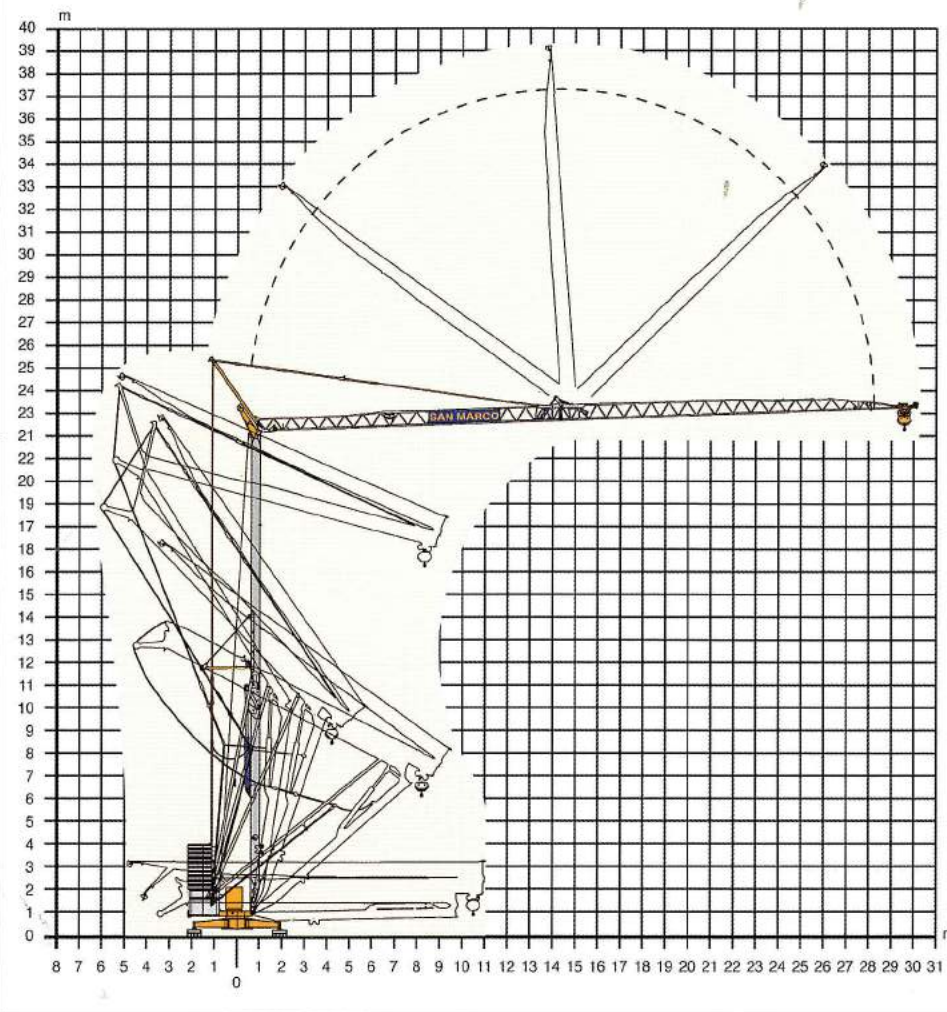

## Reazioni (F) e pesi (P)

- Reactions (F) - Loads (P)
- Eckdrücke (F) - Krangewicht (P)
- Réactions (F) - Poids (P)
- Reacciones (F) - Pesos (P)

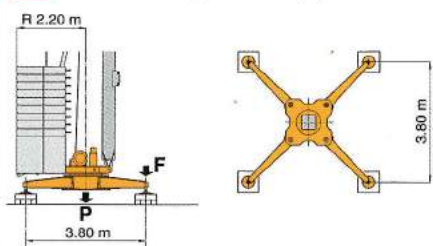

F	P	F	P
22 t	32 t	13 t	29.8 t

In servizio • In service  
In Betrieb • En service  
En servicio

Fuori servizio • Out of service  
Ausser Betrieb • Hors service  
Fuera de servicio

## Diagrammi di carico

- Loads diagrams
- Lastkurven
- Courbes de charges
- Curvas de carga

Braccio impennato  
Inclined jib  
Schräggestellter Ausleger  
Flèche relevée  
Flecha inclinada

Carrello traslante  
Traversing trolley  
Verfahrbare Laufkatze  
Chariot distributeur  
Carro distribuidor

Kg	28	30
700	27.00 m	29.00 m

Braccio orizzontale  
Horizontal jib  
Flèche horizontale  
Waagerechter Ausleger  
Flecha horizontal

Kg	28	30
2000	14.70 m	14.35 m
1800	16.17 m	15.78 m
1600	18.00 m	17.56 m
1400	20.32 m	19.82 m
1200	23.80 m	22.80 m
1000	28.00 m	26.90 m
900		30.00 m

Freccia chiusa  
Closed jib  
Auslegerspitze zu  
Flèche fermée  
Flecha plegada

Kg	28	30
2000	13.90 m	

## Potenza elettrica necessaria

- Power requirement
- Anschlusswert
- Puissance électrique nécessaire
- Potencia eléctrica necesaria

T/I*	
kW	15

## Alimentazione elettrica

- Mains supply
- Netzstrom
- Réseau électrique
- Alimentación eléctrica

T/I*	
V	380 (±5%)
Hz	50

## Carrello

- Trolley
- Katzfahren
- Chariot
- Carro

	T	I*
m/min	18 36 18 36	
kW	0.75 1.5 1.8	
Hp	1 2 2.5	

## Sollevamento

- Hoisting
- Heben
- Levage
- Elevación

	T			I*		
m/min	5	20	40	5	20	40
kg	2000	2000	1000	2000	2000	1000
kW	1.7	6.6	8.1	7.5		
Hp	2.3	9	11	10		

## Rotazione - Inverter

- Slewing - Speed controller
- Schwenken - Unrichter
- Orientation - Variateur
- Orientación - Variador

tr/min	U/min	0-1
rpm	g/min	2.3
kW		2.3
Hp		3

## Trasporto

- Transportation
- Transport
- Transport
- Transporte

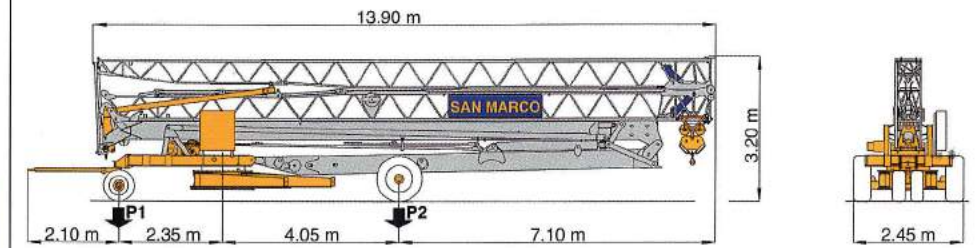

**P1 1800 kg P2 9300 kg**  
**P1 + P2 11100 kg**

Con assali senza zavorra • With axles without ballast • Mit transportachse ohne Ballast • Avec essieux sans lest • Con ejes sin contrapeso

## Assali sterzanti - spostamento laterale\*

- Steering axles - lateral displacement\*
- Steuerbare Achsen - Seitenzustellung\*
- Essieux pivotants - Déplacement latéral\*
- Eje direccional - Desplazamiento lateral\*

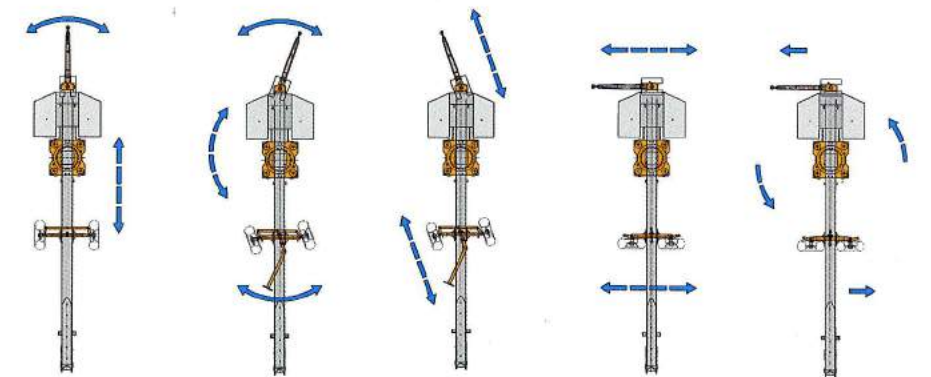

Sterzante	Doppio sterzante	Spostamento obliquo	Spostamento laterale	Rotazione 360°
Steering	Double steering	Oblique displacement	Lateral displacement	Rotation 360°
Simple pivotant	Doppelsteuerbar	Schräge bewegung	Seitenzustellung	Drehung 360°
Direccional	Double pivotant	Displacement transversal	Displacement lateral	Virage 360°
	Direccional doble	Desplazamiento oblicuo	Desplazamiento lateral	Giro 360°

- \* a richiesta • on request • auf Wunsch • sur demande  
sobre demanda
- T trifase • 3phase • dreiphasig • triphase • trifasica  
inverter • speed controller • Unrichter • variateur • variador
- I lontano sbraccio (sx) - vicino sbraccio (dx) • distant jib (sx) - near jib (dx) • Ausladung fern (sx) - Ausladung nah (dx) • fleche lointain (sx) - fleche proche (dx) • carro punta (sx) - carro torre (dx)
- salita sollevamento (sx) - discesa sollevamento (dx) • load block up (sx) - load block down (dx) • Heben Hebevorgang (sx) - Senken Hebevorgang (dx) • montée levage (sx) - descente levage (dx) • subida de gancho (sx) - bajada de gancho (dx)
- rotazione sinistra (sx) - rotazione destra (dx) • left rotation (sx) - right rotation (dx) • Drehung links (sx) - Drehung rechts (dx) • orientation gauche (sx) - orientation droite (dx) • giro izquierda (sx) - giro derecha (dx)

